

Insert your company name
Address
ZIP and town
Telephone

Manufacturer:	Model:
chassis number:	Driven km / miles:
Licence plate no.:	Tyre pressure: (psi)left part: ___ ___ ___ ___
Vehicle owner:	right part: ___ ___ ___ ___

Measurement report for wheel alignment

Camber, Caster, SAI / KPI, Toe-out-on-turns, Out of square Single Toe, Total Toe, Axle Offset	measured data in degrees [°] measured data in millimetre [mm]
--	--

before alignment		after alignment
	Camber	
	Toe left	
	Caster	
	SAI / KPI	
	Toe-out-on-turns	

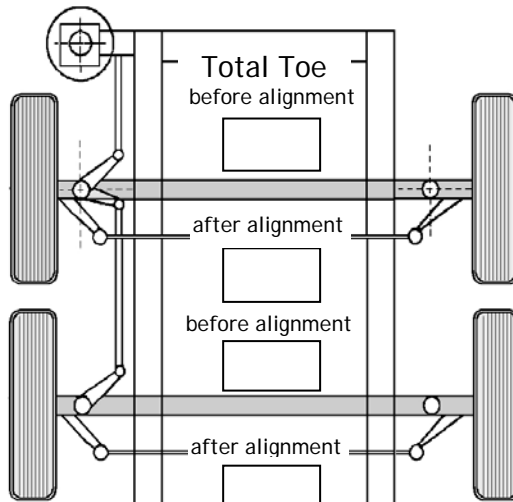

before alignment		after alignment
	Camber	
	Toe right	
	Caster	
	SAI / KPI	
	Toe-out-on-turns	

before alignment		after alignment
	Camber	
	Toe left	
	Caster	
	SAI / KPI	
	Toe-out-on-turns	

before alignment		after alignment
	Camber	
	Toe right	
	Caster	
	SAI / KPI	
	Toe-out-on-turns	

before alignment		after alignment
	Camber	
	Out of square	
	Axle Offset	

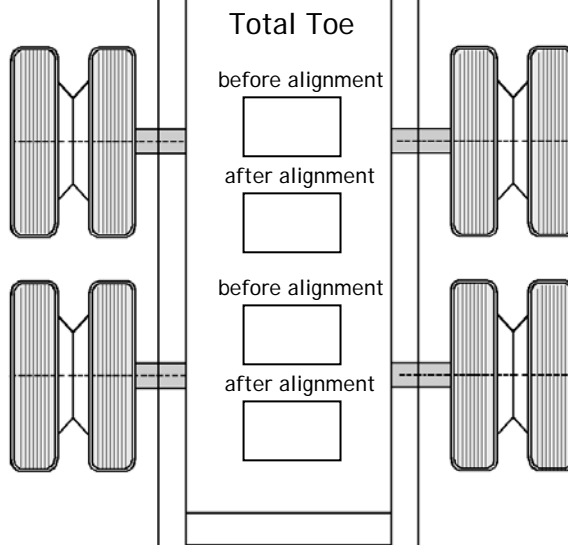

before alignment		after alignment
	Camber	
	Out of square	
	Axle Offset	

before alignment		after alignment
	Camber	
	Out of square	
	Axle Offset	

before alignment		after alignment
	Camber	
	Out of square	
	Axle Offset	

Mechanic:	Date:
Notes for Vehicle:	