

BikeBoss

Balancing Stand for Motorbike Wheels

Item No. 825 000 000
002
003



Operating Instructions

(Translation of the Original Operating Instructions)

GEB 001 170

Table of Contents

1.	GENERAL SAFETY INSTRUCTIONS	4
1.1	Important instructions for ensuring safety when using.....	5
1.2	Explanation of symbols.....	6
2.	PRODUCT DESCRIPTION.....	6
2.1	Authorised intended use	6
2.2	Technical Data.....	7
2.3	Description of device	8
3.	SCOPE OF DELIVERY	9
3.1	Parts list for the BikeBoss and upgrade kits, including accessories	9
3.2	Overview of clamping devices	10
4.	OPERATING PANEL FUNCTION DESCRIPTION.....	11
4.1	Selection menu for the settings	12
5.	PREPARATION FOR MOUNTING THE WHEEL ON THE BIKEBOSS.....	14
5.1	Clamping the motorbike wheel on the BikeBoss.....	14
6.	CARRYING OUT A MEASUREMENT.....	19
6.1	Record the setting values	19
6.2	Enter the setting values	20
6.3	First, start the measurement.....	21
6.4	Measurement complete, removing the wheel	23
7.	CALIBRATING AND MAINTENANCE	24
7.1	Calibrating	24
7.2	Care and maintenance	27
8.	TROUBLESHOOTING	28
8.1	Possible errors on the system	28
9.	SPARE PARTS	29
10.	DISPOSAL.....	31
10.1	Instructions for disposal of electrical appliances in the EU member states.....	31
11.	EC DECLARATION OF CONFORMITY	32
12.	OVERVIEW OF THE MOTORBIKE DATA.....	33

Last updated: February 2020

Subject to technical modifications.

Version 3

Figures: HAWEKA AG / D-30938 Burgwedel

Reproduction in any form is not permitted.

1. General Safety Instructions



The balancing stand has been designed and built after careful selection of applicable harmonised standards. Thus, it conforms to the current state-of-the-art technology and provides the highest degree of safety during operation.

The balancing stand may only be structurally modified with written authorisation by the manufacturer!

Device safety can only be implemented during practical operation if all required applicable measures have been taken. The operator's duty of care includes planning such measures and checking their implementation.

In particular, the operator has to ensure that

- the device is only used for its intended purpose
- the device is only used in a fully functioning state and free from defects
- the complete operating instructions are permanently available in a readable condition at the operating location of the device
- the device is only operated by accordingly qualified and authorised personnel
- personnel are regularly instructed in all relevant health and safety issues and are familiar with the operating instructions, in particular with the safety instructions contained therein

1.1 Important instructions for ensuring safety when using



Ensure that hair, loose clothing, ties, chains and all body parts are kept clear of moving equipment components.



Ensure that the mains power cable does not come in contact with any moving parts.



Wear safety goggles when using the balancing stand.



Use protective or working gloves.

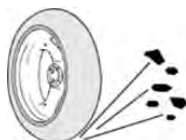

Before balancing, remove old compensating weights and loose parts from the rim and tyres.



Observe the basic principles for the lifting of loads.
Heavy loads should not be lifted without assistance.



Observe all operating instructions and warning notices that are attached to the device.



Labels on the BikeBoss must neither be removed nor made unrecognizable. Missing or illegible labels should be immediately replaced.



Note

The user is independently responsible for proper operation and compliance with safety regulations.

1.2 Explanation of symbols

These operating instructions contain specific safety instructions. The following symbols are used for this purpose:



Attention

This symbol indicates potential danger to the device and material.



Warning if injuries

This symbol indicates potential danger to persons.



Note

This symbol does not indicate a safety instruction; it indicates information provided for a better understanding of work procedures.

2. Product Description

2.1 Authorised intended use

The BikeBoss	is a balancing stand for motorbike wheels and must only be installed at dry locations that are protected against dripping water.
The BikeBoss has	been developed and built in order to balance motorbike wheels statically and / or dynamically (from 3 inch wheel width).
The BikeBoss is only used	to balance removed motorbike wheels that are within the range of the given technical specifications.
The BikeBoss must	only be used for wheels up to a max. overall weight of 30 kg and up to a max. wheel diameter of 21 inches.
The BikeBoss facilitates	reliable assertion about the imbalance of a motorbike wheel when used correctly and the wheel is correctly clamped!

For correct and safe use of the BikeBoss, ensure that the ambient lighting is a minimum of 300 Lux and a working temperature of 10 °C to +50 °C.



Before use, the BikeBoss must be approximately at the same temperature as the ambient temperature.



Note

The operating company of the BikeBoss and not the manufacturer, is responsible for all injury to persons and tangible damage that occurs if used not as intended.

2.2 Technical Data

Wheel diameter	12 to 23 inch
Max. wheel width	400 mm (15.5 inches)
Max. weight of wheel when using the 15 mm shaft	15 kg
Max. weight of wheel when using the 19.05 mm shaft	30 kg
Input power supply	12 V DC 1.0 A
Temperature of the working environment	from 10° to 50° C
Average measurement time (4 revolutions)	approx. 3 sec.
Measurement speed	90 rpm
Weight	47 kg

Automatic switching to the static measurement value is carried out with a wheel width of less than 2.5" (63 mm).

Device dimensions in [mm]

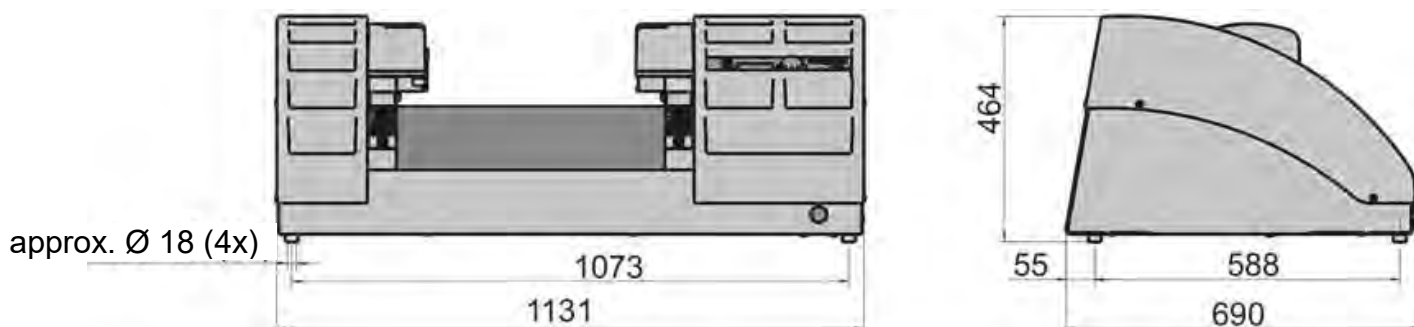

Optional accessories: Support table / base

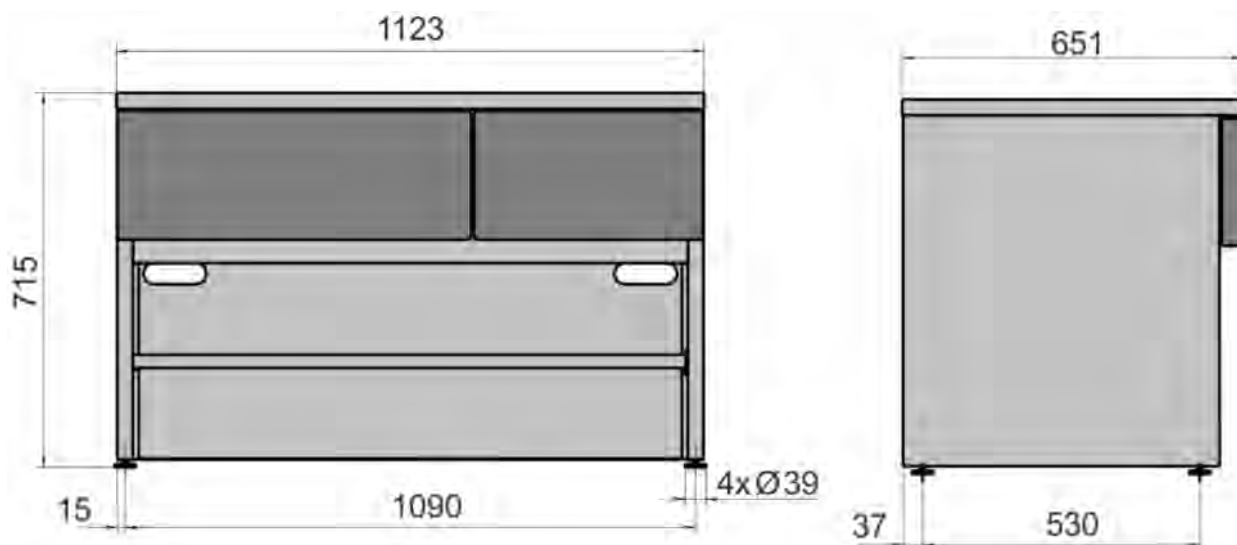

2.3 Description of device

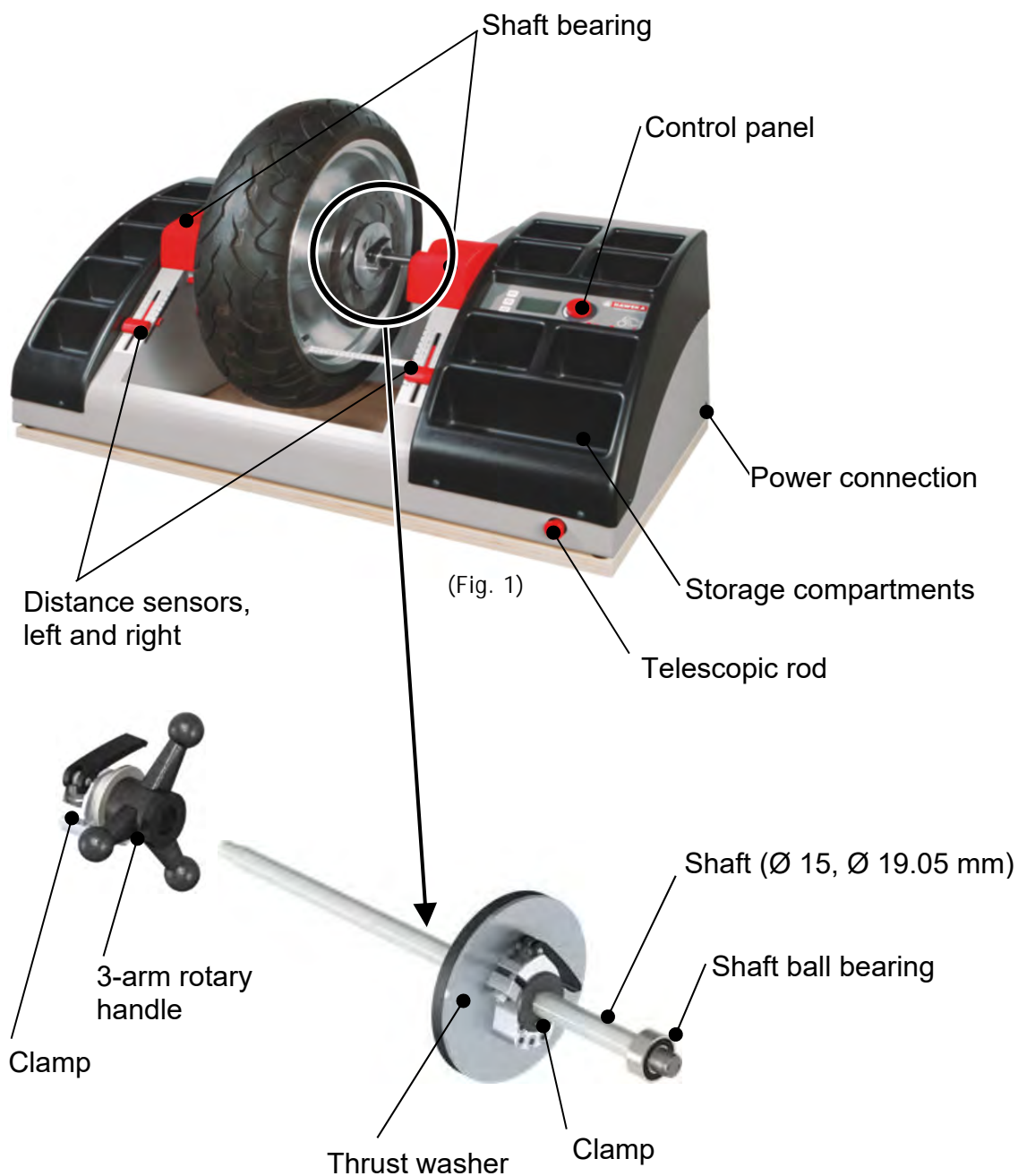

Power connection:

Before using the BikeBoss, the operator must connect the power supply unit (110 / 230 V) supplied to their own power connection and connect the cable to the socket for the power connection on the BikeBoss.

For longer periods without use, the power supply unit should be disconnected from the socket.

3. Scope of Delivery

3.1 Parts list for the BikeBoss and upgrade kits, including accessories

Item No.

825 000 000 BikeBoss "Basic" incl. shaft Ø 15 mm and accessories

825 001 088	1 x	BikeBoss balancing stand
825 001 074	1 x	Shaft Ø 15 mm (with self-aligning ball bearing)
825 001 049	1 x	Thrust washer with clamp
825 001 060	1 x	3-Arm rotary handle with clamp
825 001 048	2 x	Clamping sleeve for Ø 15 mm shaft
D00630 2202	2 x	Plug-in self-aligning ball bearing individual (1x of these spare)
825 001 002	1 x	12V Power supply unit for the power supply
860e150 170	2 x	Locating sleeve Ø 17 mm
860e150 200	2 x	Locating sleeve Ø 20 mm

825 000 002 Upgrade kit "Locating sleeves" incl. shaft Ø 19.05 mm

825 001 051	1 x	Shaft Ø 19.05 mm (3/4") (with self-aligning ball bearing)
825 001 044	2 x	Clamping sleeve for Ø 19.05 mm shaft
860e190 220	2 x	Locating sleeve Ø 22 mm
860e190 250	2 x	Locating sleeve Ø 25 mm
860e190 254	2 x	Locating sleeve Ø 25.4 mm
860e190 261	2 x	Locating sleeve Ø 26 mm
860e190 280	2 x	Locating sleeve Ø 28 mm
860e190 300	2 x	Locating sleeve Ø 30 mm
860e190 320	2 x	Locating sleeve Ø 32 mm
860e190 350	2 x	Locating sleeve Ø 35 mm



















825 000 003 Upgrade kit "Locating sleeves" monolever

860e190 004	1 x	Locating sleeve DUCATI / TRIUMPH
860e190 011	1 x	Locating sleeve MV AGUSTA / HONDA
860e190 012	1 x	Locating sleeve APRILIA / BMW / DUCATI / YAMAHA
860e190 018	1 x	Locating sleeve HONDA GL 1800/NTV 650
860e150 015	1 x	Locating disc BMW I (to year of man. 2005) except R 1200 GS
860e190 020	1 x	Locating disc BMW I (from year of man. 2005) also R 1200 GS
860e190 024	1 x	Locating sleeve HONDA VFR1200 (from year of man. 2010)/TRIUMPH
860e190 022	1 x	Locating flange TRIUMPH (from year of man. 2005) / KTM Superduke

825 001 000 Base cabinet BikeBoss

1 x	Base cabinet (incl. inserts)
-----	------------------------------

3.2 Overview of clamping devices

Item No.	Clamping device for single arm rocker	Figure
860e190 004	Locating sleeve Ducati	
860e190 011	Locating sleeve MV Agusta / Honda	
860e190 012	Locating sleeve Aprilia / BMW / Yamaha GTS1000	
860e190 018	Locating sleeve HONDA: NTV 650, Goldwing 1800	
860e150 015	Locating sleeve BMW (up to 2005)	
860e190 020	Locating disc BMW (from 2005)	
860e190 024	Locating disc Triumph , Honda VFR1200	
860e190 022	Locating flange KTM Superduke, Triumph (diverse from 2011)	
Item No.	Clamping device for stud axle	Figure
860 150 170	2 Locating sleeves 17 mm – for shaft Ø 15 mm	
860 150 200	2 Locating sleeves 20 mm – for shaft Ø 15 mm	
860 190 220	2 Locating sleeves 22 mm – for shaft Ø 19.05 mm	
860 190 250	2 Locating sleeves 25 mm – for shaft Ø 19.05 mm	
860 190 254	2 Locating sleeves 25.4 mm – for shaft Ø 19.05 mm	
860 190 261	2 Locating sleeves 26 mm – for shaft Ø 19.05 mm	
860 190 280	2 Locating sleeves 28 mm – for shaft Ø 19.05 mm	
860 190 300	2 Locating sleeves 30 mm – for shaft Ø 19.05 mm	
860 190 320	2 Locating sleeves 32 mm – for shaft Ø 19.05 mm	
860 190 350	2 Locating sleeves 35 mm – for shaft Ø 19.05 mm	

4. Operating Panel Function Description

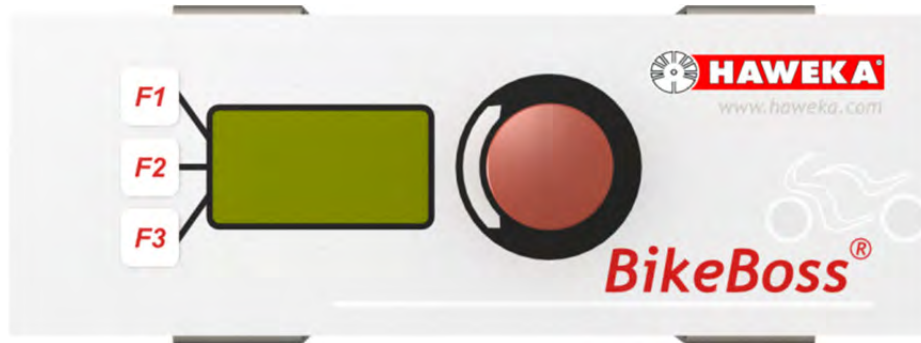

(Fig. 2)

When the BikeBoss is switched on, the start menu appears on the screen.

On the left side of the screen, the actual functions for the three buttons F1, F2, F3 are indicated. They have different functions, according on the menu selected.

(Fig. 3)

Example, Start screen:

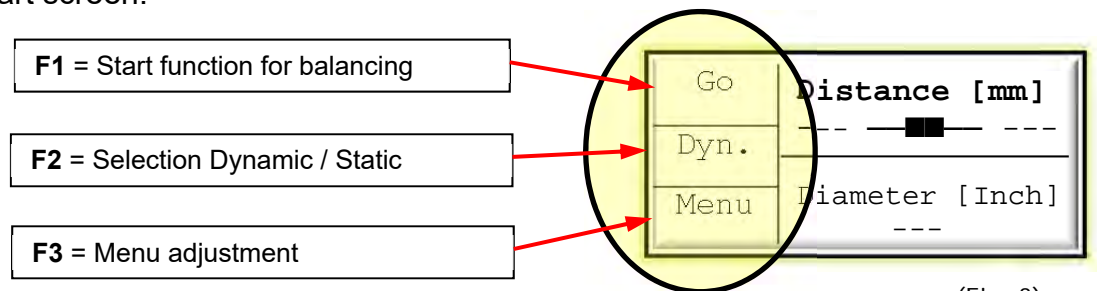

(Fig. 3)

Button F1: Starts a new measurement (refer to as from Page 20 Pt. 6.1 Enter values.)

Button F2: Switching between static and dynamic measuring.

i If the width of the rim is **less than 2.5 inches**, static measurement is automatically switched.

Note

Button F3: Menu adjustment (refer to the next page Pt. 4.1)

The rotary knob is used for input and selection. (Fig. 4)

ROTATE = Select values
PRESS = Confirm selection

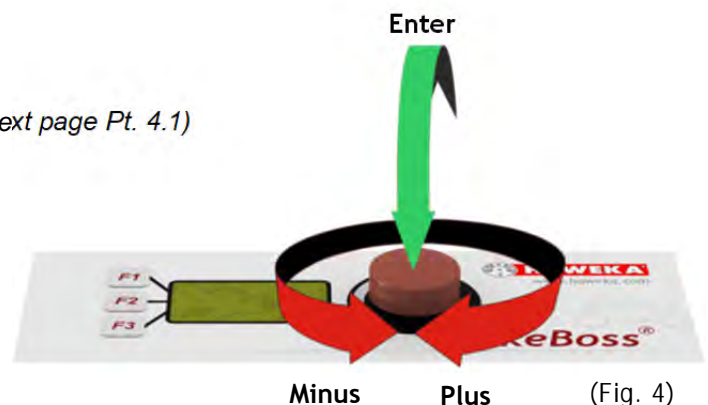

(Fig. 4)

i If the rotary knob is pressed for a longer period of time, the program reverts to the main menu

Note

4.1 Selection menu for the settings

F3 In the start menu, press the button F3.
(Fig. 3)

On the screen, in the setup menu, the selection is again by using the function buttons.

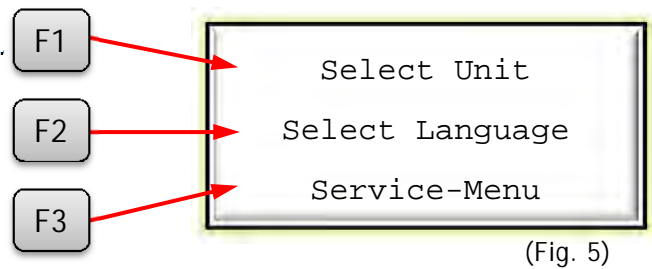

(Fig. 5)

Button F1: Set the unit



Selection as to whether measurement should be in Gram [g] or Ounces [oz]. Changing between the units is achieved by rotating and pressing the rotary knob. The active selection is indicated by enlarged script.

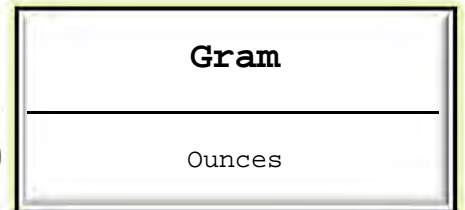

(Fig. 6)

The display automatically changes to the selection for the resolution of the measurement result to be indicated on the display.

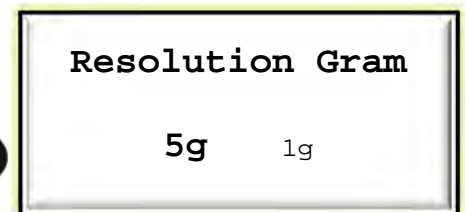

or

The display resolution is selected by rotating and pressing the rotary knob. The table shows the indicated values [Gram] on the display for 5g and 1g.

5g	1g
0	0
5	1
10	2
15	3
20	4
25	5

Example:

If the imbalance is 17 grams, the display indicates 5g = 15g for the selected resolution, for the resolution 1g = 17g.

Only for 1g (1/16 oz) indication:

If the display resolution was set to 1g (1/16 oz), the value for the remaining value suppression is subsequently selected (rotating and pressing the rotary knob)

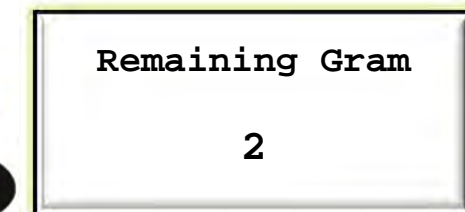
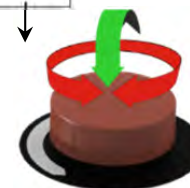

or

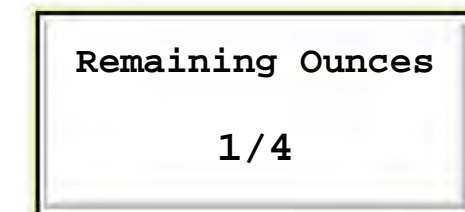

(Fig. 8)

Gram = 1 to 5

Ounces = 1/4 - 1/8 - 1/16

This means that if the result of the measurement is smaller/equal to the remaining value selected, "0" is indicated on the display.

Button F2: Setting the language

F2

The program can be set to different languages.

The selection made is activated by rotating and pressing the rotary knob.
(Fig. 10)

The program reverts to the language selected in the menu setting.

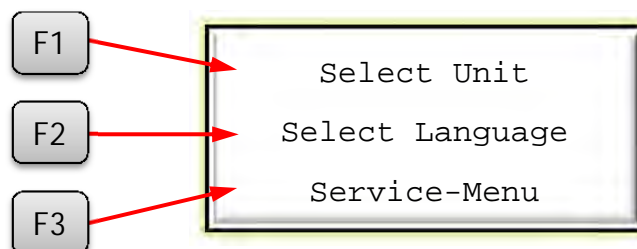

(Fig. 9)

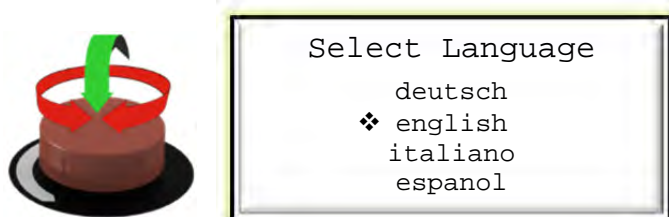

(Fig. 10)

Button F3: Service menu

F3

In the service menu, there are two selection options that can be selected by pressing the function buttons.

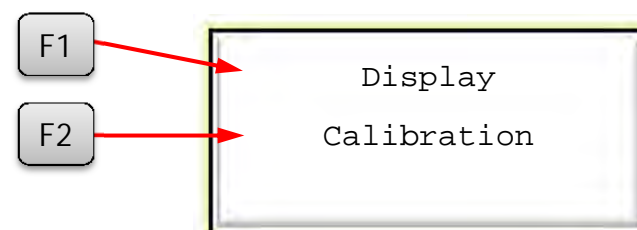

(Fig. 11)

Button F1

Here, the display contrast is set. The new value is saved using button F1.



(Fig. 12)

i By pressing the rotary knob for an extended period, the procedure is cancelled and the previous display contrast is re-established.

Note

Button F2

By pressing button F2, the calibration function is called up. Here, refer to Chapter 7.1 (Page 24).

5. Preparation for Mounting the Wheel on the BikeBoss

5.1 Clamping the motorbike wheel on the BikeBoss

Selection of the correct mounting shaft

There are two different mounting shafts for the BikeBoss.



The suitable shaft diameter depends on the mounting holes of the motorbike wheel (refer to the list in the Appendix).

Preparation for mounting the wheel.

First, select the suitable clamping sleeve for the mounting shaft. (Fig. 14) It must be suitable for the diameter of the shaft. (Fig. 13)

i Note Two clamping sleeves are required for each shaft.

One of the sleeves is inserted into the clamp using the 3-Arm rotary handle. (Fig. 15)

i Note The sleeves can only be inserted when the bar on the clamp is open.

To firmly seat the sleeve, it is rotated until the elongated hole butts against the stop on the screw on the clamp. (Fig. 16)

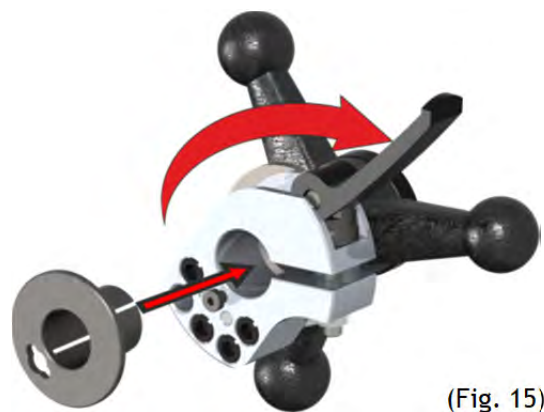

The second sleeve is inserted into the clamp by the thrust washer and also locked. (Fig. 17)



(Fig. 17)

To preset, the thrust washer is pushed by the clamp to the rear third of the mounting shaft and locked by moving down the bar on the clamp onto the shaft. (Fig. 18)

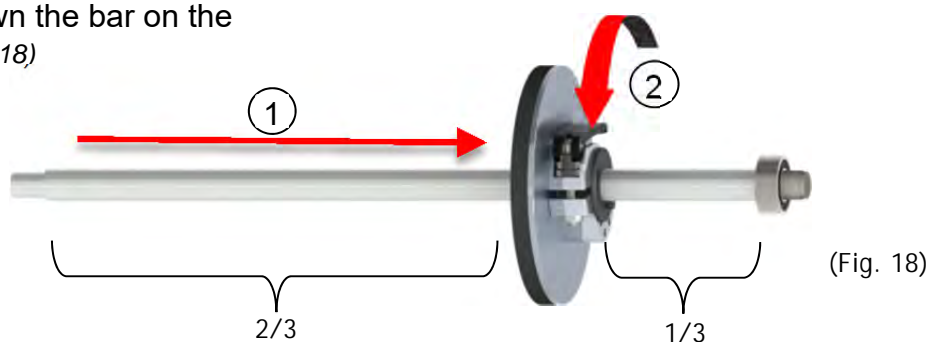

(Fig. 18)

Motorbike wheels with ball bearings can either be directly put onto the mounting shaft, or with the suitable locating sleeves.



L if the internal diameter of the bearing in the wheel is greater than the diameter of the mounting shaft.

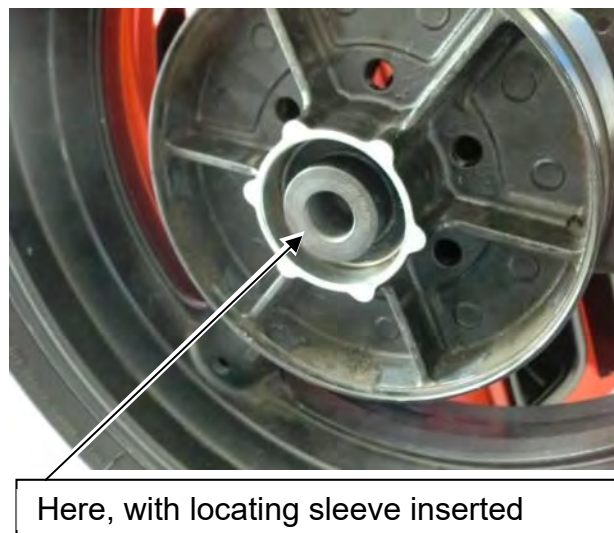

(Fig. 19)

Depending on the vehicle manufacturer, motorbike wheels with single arm rocker attachment, without bearing, require a special locating unit so that the wheel can be correctly mounted on the BikeBoss.



Refer to the overview of the locating device for single arm rockers.

The suitable locating disc is inserted on the side of the contact surface.
(Fig. 20)



Rim for single arm rocker



Insert the suitable locating disc

(Fig. 20)

The telescopic rod is suited to connect the shaft and locating disc to the wheel on the BikeBoss at a comfortable working height.



(Fig. 21)

For motorbike wheels with a disc brake, alignment of the wheel must be selected so that the disc brake is aligned to the rubber insert of the pressure plate. (Fig. 22)



(Fig. 22)

i Fundamentally, the most sensitive side of the wheel butts against the rubber insert of the pressure plate.
Note

Subsequently, using the 3-Arm rotary handle, push the clamp tightly onto the locating disc and close the bar on the clamp. (Fig. 23)



(Fig. 23)

i For an accurate measurement, it is important that the wheel is attached to the shaft so that the elements cannot move against one another during acceleration and slowing down.
Note

In order to clamp the wheel on the mounting shaft, the 3-Arm rotary handle is rotated until the wheel rests on the rubber and is connected to the locating disc. (Fig. 24)

Do not use force!

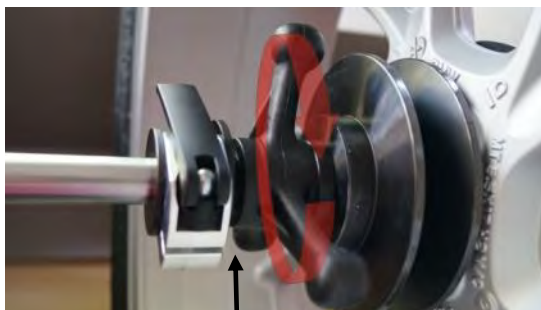

(Fig. 24)

i The thread on the 3-Arm rotary handle is visible.
Note

Inserting the wheel shaft unit:

Before the unit is placed in the BikeBoss, the shaft lowering lever must be put to the top position. (Fig. 25)



(Fig. 25)

The unit is now inserted into both bearing blocks of the BikeBoss.



Attention

The fixed ball bearing on the shaft must be located on the right side of the BikeBoss. (Fig. 26)



Note

The bearing blocks in the BikeBoss must be clean.



Front view - **right**, fixed shaft bearing

(Fig. 26)

On the left side, the shaft rests on the shaft lowering lever. Thus, the floating ball bearing can be placed on the end of the shaft in the bearing block. (Fig. 27)

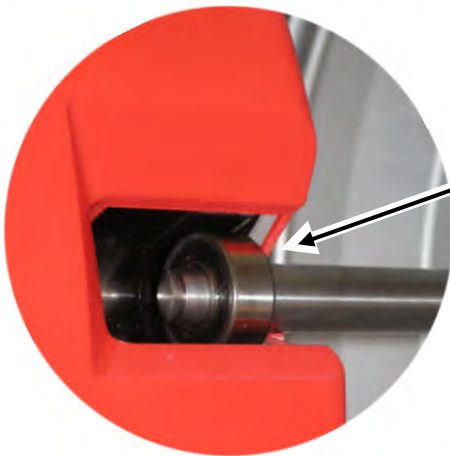

Front view - **left**, floating shaft bearing

(Fig. 27)

Subsequently, the shaft is lowered into the bearing block using the shaft lowering lever. (Fig. 28)



(Fig. 28)

6. Carrying Out a Measurement

6.1 Record the setting values

The position of the measuring tape is set on the BikeBoss for the wheel size to be measured.

(Here in the example **17 inch**, Fig. 29)



(Fig. 29)

Repeat this procedure on the other side of the BikeBoss. (Fig. 30)



(Fig. 30)

For the distance measurement, the left measuring tape is routed to the planned bonding position of the compensation weight on the rim.

The value for the left side is noted.
(Here in the example **215 mm**, Fig. 31)



(Fig. 31)

Repeat this procedure on the other side of the wheel.

The value for the right side is noted.
(Here in the example **165 mm**, Fig. 32)

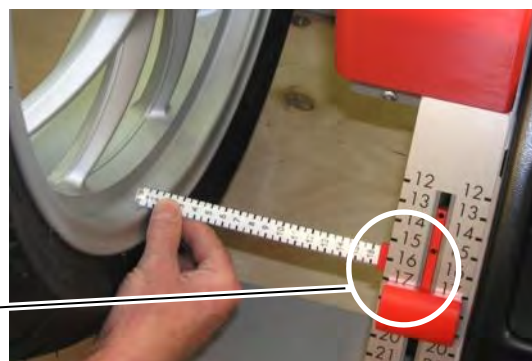

(Fig. 32)

6.2 Enter the setting values

The BikeBoss is switched on and the main menu appears on the display.

Changing between the selection is achieved by rotating and pressing the rotary knob. The active selection is indicated by enlarged script.

- Select "Distance" and press the rotary knob.

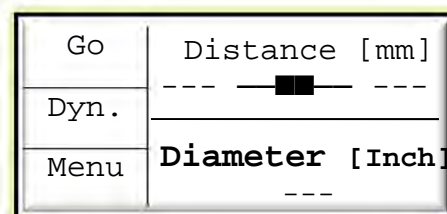

(Fig. 33)

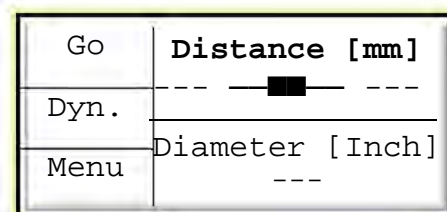

(Fig. 34)

The left distance is set first, by rotating and pressing the rotary knob. The value is accepted by rotating and pressing the rotary knob and automatically changed to the input "right".

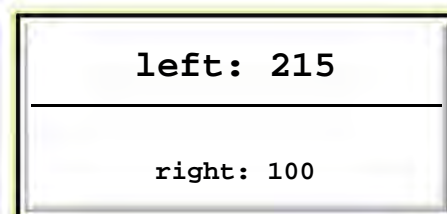

(Fig. 35)

The selection "right" is indicated by enlarged script. The input for the distance on the right is made. (Fig. 36)

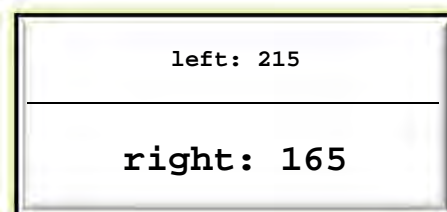

(Fig. 36)

After confirming the distance values, the main menu appears.

Subsequently, the rim diameter is selected by rotating and pressing the rotary knob.

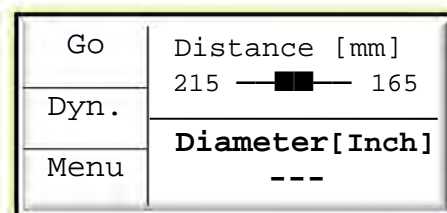

(Fig. 37)

i A rim diameter of 17.5 inches is specified as a standard value.

Note

Input is also carried out using the rotary knob

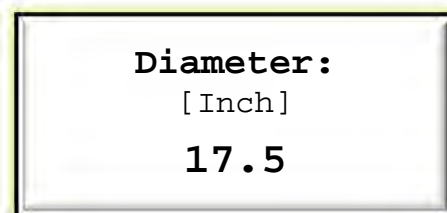

(Fig. 38)

6.3 First, start the measurement

The values entered appear on the screen of the main menu and the BikeBoss is ready for the first measurement.

- Make sure that the old compensating weights, any stones, contamination or other foreign objects have been removed from the wheel.

- To start the measurement, press the button F1.

- In order to accelerate the wheel, it must be manually rotated downwards.



Wear protective gloves to accelerate and slow down the wheel!



Wear safety goggles during the measurement!

If the wheel has been accelerated in the incorrect direction, an error message is displayed. (Fig. 41) Wait until the wheel is stationary. Only then can a measurement be carried out in the correct direction of rotation.

i Note The wheel must be accelerated so that the speed is **a min. of 3 rpm [revolutions per minute] more than the SETPOINT speed of 90 rpm.**

Now wait until the rotation speed has attained the SETPOINT value of 90 rpm. (Fig. 43)

The measurement procedure starts automatically. The duration of the measurement is presented on the display by a cumulative bar and is completed after the 4th signal tone. (Fig. 44)

i Note In order not to influence the measurement value, in this time do not touch the wheel and BikeBoss.

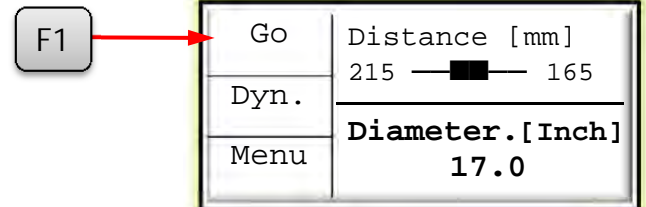

(Fig. 39)

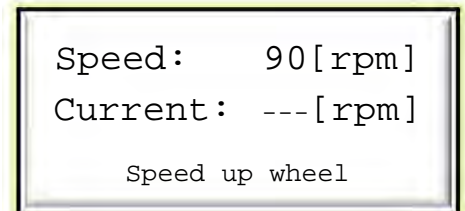

(Fig. 40)

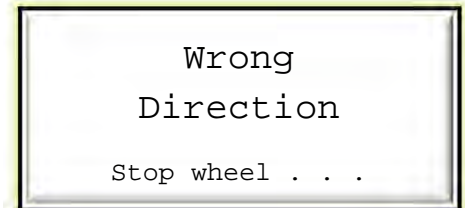

(Fig. 41)

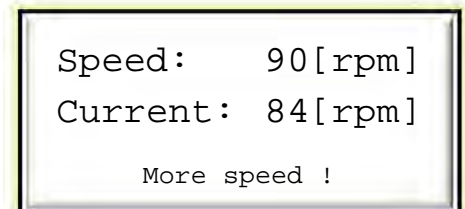

(Fig. 42)

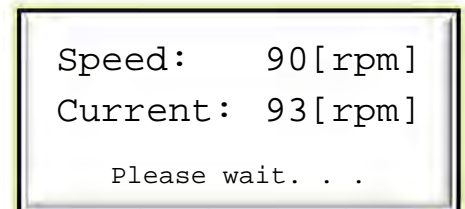

(Fig. 43)

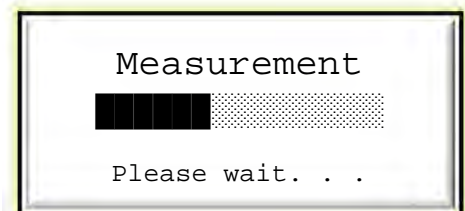

(Fig. 44)

After the measurement, slow down the wheel until it is stationary.



Use the protective gloves when slowing down the wheel!



Slow down the wheel on the wheel profile.
Do not reach into the spokes of the wheel from the side!

Only when the wheel is stationary are the calculated compensation weights displayed. For the dynamic measurement, the weights are displayed for the left and right. (Fig. 46)

The arrows on the display indicate in which direction the wheel must be rotated.

When the wheel has attained its setpoint positions, all 4 arrows are depicted and the appropriate value flashes on the display.

The compensation weight is bonded at the bottom, at the 6 o'clock position. The labels are used to detect the correct position in the BikeBoss. (Fig. 47)

After the weights have been attached, a control measurement can be started by again rotating the wheel. The normal measurement sequence is carried out. (Fig. 48)

ADDITIONAL OPTIONS AFTER THE MEASUREMENT:

F2

Using button F2, switching can be carried out between static and dynamic.

For the static measurement, the weight is only indicated centred, the arrows on the left and right each have the same indication. (Fig. 49)

By again pressing button F2, the dynamic measurement values for the compensation weights are again displayed.

```

Finished
Stop wheel...
  
```

(Fig. 45)

```

          Result          v
left           right     v
^    2           56     ^
^           turn wheel  ^
  
```

(Fig. 46)

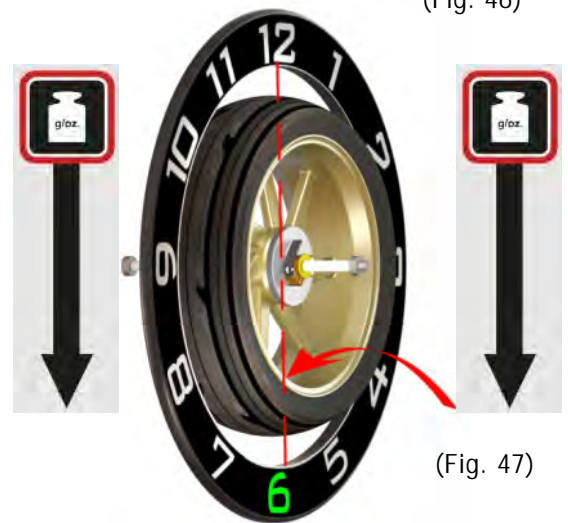

(Fig. 47)

```

Speed:      90 [rpm]
Current:    93 [rpm]

Please wait. . .
  
```

(Fig. 48)

```

v          Result          v
v          static          v
           58
           turn wheel
  
```

(Fig. 49)

F3

By pressing button F3, the input values can again be displayed. (Fig. 50)

After 5 seconds, or again pressing the button F3, the measurement values attained for the compensation weights can be viewed again on the display. (Fig. 46)

i**Note**

For the special software version of the BikeBoss for production companies, the input values also remain preserved if the shaft has been removed from the bearing blocks.

F1

Using button F1, all input values are deleted and a completely new measurement is started. There is again the request for distance and rim diameter. (Fig. 51).

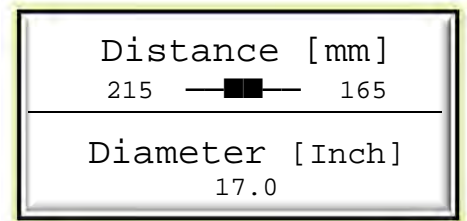

(Fig. 50)

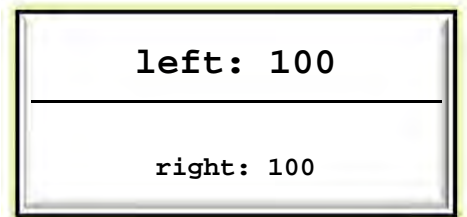

(Fig. 51)

6.4 Measurement complete, removing the wheel

When the balancing procedure is completed and the imbalance of the wheel has been rectified, the wheel is removed from the BikeBoss in the reverse sequence.

The shaft lowering lever is pushed upwards until the ball bearing rests free in the bearing block. (Fig. 52)

The ball bearing can now be removed from the shaft.



(Fig. 52)

Subsequently, the unit can be lifted out of the BikeBoss and suspended on the telescopic rod by the wheel. (Fig. 53)



(Fig. 53)

First, the 3-Arm rotary handle is rotated anticlockwise, so that the unit is released. (Fig. 54)

Only then is the bar on the 3-Arm rotary handle opened and pushed downwards away from the shaft.

Now hold the wheel and pull out the shaft with the pressure disc.

i Note If using locating elements for single arm rockers, these can become loose and fall from the wheel.

When pulling out the locating elements, firmly hold the wheel. (Fig.55)



(Fig. 54)



(Fig. 55)

7. Calibrating and Maintenance

7.1 Calibrating

Calibration should only be carried out if the quality of the balancing is not optimal. That means, the wheels have been correctly balanced, however, noticeable imbalance has occurred on the motorbike whilst riding that could be rectified using another balancing device. Calibration is also required if illogical measurement values are displayed. A medium sized balanced wheel is required to calibrate, ideally a 6 inch wide wheel with its own bearings. The balanced wheel should have been previously balanced to “zero” gram with preferably no imbalance.

Firstly as described in 4.1, convert the resolution settings to 1 gram or 1/16 ounce.

i Note Two measurement cycles are required for the calibration. The first cycle is carried out using the zero wheel.

Install the zero wheel on the shaft and place it into the balancing stand.

- On the start screen, select the main menu using button F3. (Fig. 56)
- Again select the button F3 for the service menu. (Fig. 57)

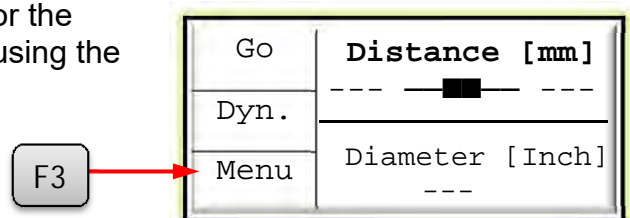

(Fig. 56)

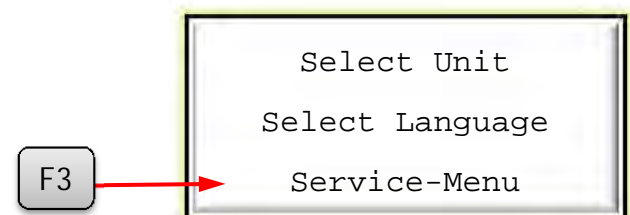

(Fig. 57)

- In the service menu, select the button F2 for the calibration.
- Using the right measuring tape, measure to the centre of the wheel and enter the value. (Fig. 59 + 60)

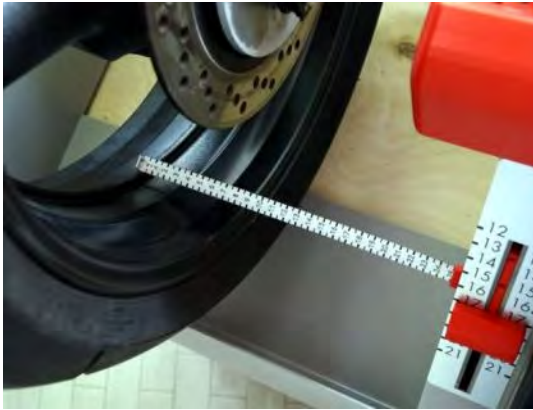

(Fig. 59)

- Subsequently, enter the diameter of the wheel.
- Start the measurement by accelerating the wheel.



The wheel must be accelerated so that the speed is a min. of 3 rpm [revolutions per minute] more than the SETPOINT speed.

When the wheel has attained the measurement speed, the measurement starts.

- After the first measurement, the wheel must be slowed down until it is stationary.



When slowing down the wheel, wear protective gloves!

F2

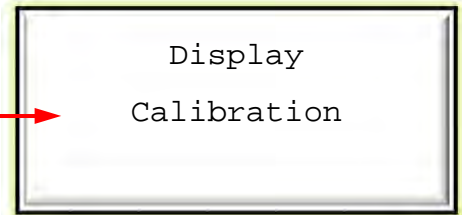

(Fig. 58)

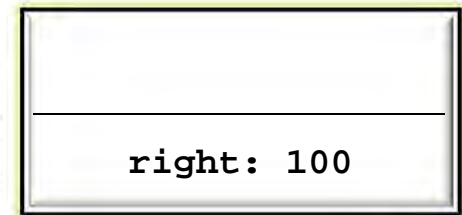

(Fig. 60)

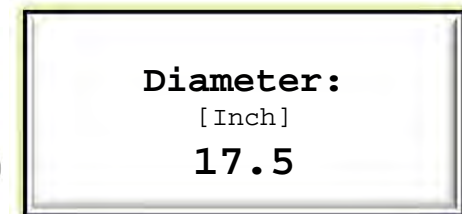

(Fig. 61)

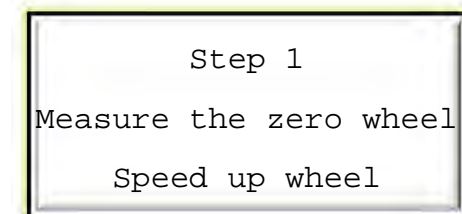

(Fig. 62)

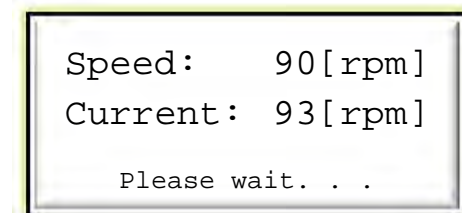

(Fig. 63)

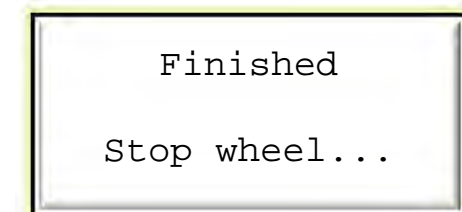

(Fig. 64)

- Rotate the wheel until the actual angle (**Act. angle**) agrees with the calibration angle (**Cal. angle**). (Fig. 65)

Step 2

Cal. weight	60 gr
Cal. angle	180 degrees
Act. angle	179 degrees
Continue =	ENTER

(Fig. 65)

- The calibration weights (2 x 30 gr) or (2 x 1 oz) are bonded at 180 degrees (6 o'clock position) on the left and right and a new measurement is carried out.

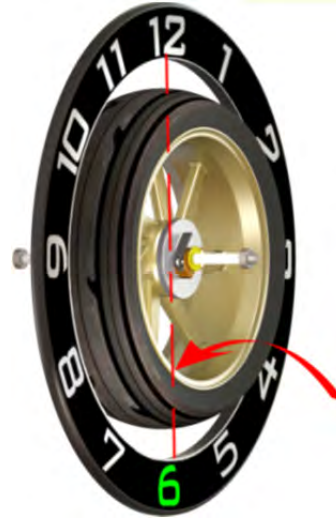

(Fig. 66)

- The second measurement is started using the button **ENTER** (pressing the rotary knob). (Fig. 66)

**Note**

Step 3 (second measurement) can only be started when the actual angle is in the range of + - 10 degrees to the calibration angle.

Accelerate the wheel to the measurement speed and start the second measurement.

- After the measurement, the wheel is slowed down until it is stationary.



When slowing down the wheel, wear protective gloves!



Using the button **F1**, the new calibration values calculated are saved. (Fig. 70).

**Note**

By pressing the rotary knob for an extended period, the new calibration values can be discarded

**Note**

A repeat of the calibration process can increase the accuracy

- After the calibration process revert back to the original resolution settings as per 4.1

Step 3

Calibration run
Speed up wheel

(Fig. 67)

Speed: 90 [rpm]
Current: 93 [rpm]

Please wait. . .

(Fig. 68)

Finished

Stop wheel...

(Fig. 69)

Step 4

Calibration result

P1 58398	P3 28570
P2 58398	P4 28570
	W -151

Save with F1

(Fig. 70)

7.2 Care and maintenance



Please note that the BikeBoss, with its clamping devices, is a technical, sensitive measuring device. These components must be used and maintained with great care at all times.

- Both support surfaces in the bearing blocks must always be kept free of contamination. If the bearing shells are contaminated, use a dry cloth to clean them. Only thus can a correct measurement be ensured. (Fig. 71)

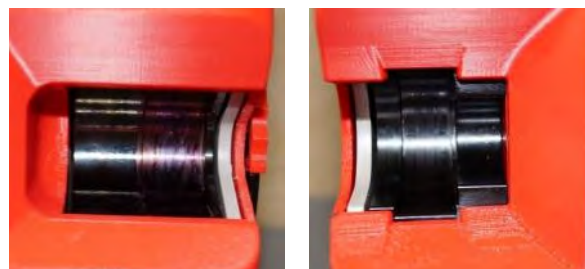

(Fig. 71)

- Before installing the ball bearing, check that the bearing rings run easily and are clean. Before using each time, it is recommended to clean the bearing rings using a soft cloth.

(Fig. 72)



(Fig. 72)



Attention

If it is not ensured that the ball bearing can run easily, replace the ball bearing.

- In order to replace the ball bearing stuck on the shaft, first remove the magnetic screw from the shaft. Then, the ball bearing can be removed from the shaft. (Fig. 73)



(Fig. 73)



Note

The maximum magnetic screw tightening torque is 5nm

- The mounting shaft must always be kept free from contamination and grease.
- If the clamping force of the clamp on the shaft is no longer sufficient, this can be adjusted by tightening the nut. (Fig. 74)
- Check the tilting lug for ease of movement and, as necessary, apply a little grease or lubricant between the tilting lever and cam. (Fig. 74)

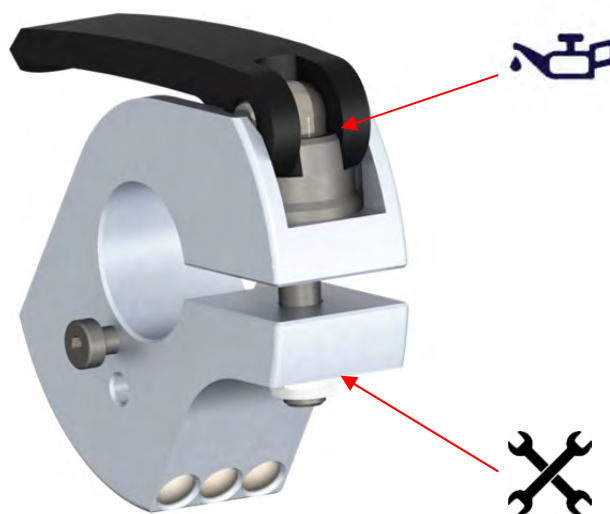

(Fig. 74)

- In every case, a continuous check of the clamping device used is necessary! It must be ensured that the clamping devices are not worn. (Fig. 75)
- The locating sleeves required must be inserted exactly into the respective wheel mounting. Loose seating of the locating sleeves inevitably results in errors when measuring.

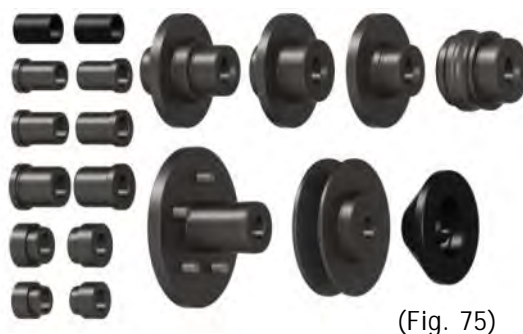

(Fig. 75)

A correctly balanced wheel when again installed on the BikeBoss (by releasing the wheel + shaft unit and rotating the wheel on the shaft) should not result in imbalance by more than 10 grams.

Should greater differences be determined, the clamping device must be thoroughly checked and, as necessary, replaced.

8. Troubleshooting

8.1 Possible errors on the system



Operators may only redress errors that are clearly the result of operating or maintenance errors!

In the following overview, some possible errors are listed that can be rectified by the operator themselves. For all other cases, the technical customer service is responsible. For this, please contact your dealer.

Description	Possible causes	Troubleshooting
<ul style="list-style-type: none"> • No indication on the display. Display does not illuminate. 	<ul style="list-style-type: none"> • Power supply unit not connected. • Power connection defective. • Power supply unit defective 	<ul style="list-style-type: none"> • Check the power supply unit at the power connection • Connect the cable of the power supply unit into the socket of the BikeBoss • Check the main connection • Replace the power supply unit
<ul style="list-style-type: none"> • Excessive deviation for repeat measurements 	<ul style="list-style-type: none"> • The bearing shells are heavily contaminated. • The ball bearings are contaminated or rotate with difficulty • The clamps have excessive play at the shaft or wheel 	<ul style="list-style-type: none"> • Clean the bearing shells. • Clean the bearing rings of the ball bearing. • Replacing the ball bearing. • Replacing the tensioning aids required. Contact your dealer

Description	Possible causes	Troubleshooting
<ul style="list-style-type: none"> Excessive deviation for repeat measurements 	<ul style="list-style-type: none"> The wheel is insufficiently clamped onto the shaft and rotates 	<ul style="list-style-type: none"> Replace the wheel on the shaft and check for firm seat. (The wheel must not be able to be rotated on the shaft)
<ul style="list-style-type: none"> Measurement results are not realistic 	<ul style="list-style-type: none"> Incorrect wheel data entered Adjustment of the system no longer correct. Error on the rim or on the wheel bearings 	<ul style="list-style-type: none"> Check the wheel data and again enter. Calibration required (refer to Pt. 7.1) Visual check of the rim and bearing. If these are damaged, replace the rim / bearing.
<ul style="list-style-type: none"> Measuring tape for measuring the distance jams 	<ul style="list-style-type: none"> Bent or contaminated surface Resetting defective 	<ul style="list-style-type: none"> Use a clean cloth and clean the surface. Replacement required - Contact your customer service.
<ul style="list-style-type: none"> Excessive vibrations occurred during the measurements, the error message "Brake wheel..." is output 	<ul style="list-style-type: none"> The wheel is not clamped tightly enough. There is a loose part in the tyre - noises can be heard when the wheel turns. Disk on centring shaft of the right bearing is bent 	<ul style="list-style-type: none"> Adjust clamping force of the eccentric lever for wheel tension on the nut (see item 7.2 fig. 74). Separate the tyre from the rim and clean the tyre inside and outside. Replace the disc (825 001 070) on the centring shaft.

9. Spare Parts

Eccentric spanner:

Item No. DU EX6306

Hexagon nut M6:

Item No. D00985 00006

Washer:

Item No. D00 125 00006

Self-aligning ball bearing:

Item No. D00630 2202

Thrust washer with rubber insert:

Item No. 825 001 055

Magnetic screw:

Item No. 825 001 038

Anti-rotation lock / disc 15x31x1

Item No.. 825 001 070



Spare Parts

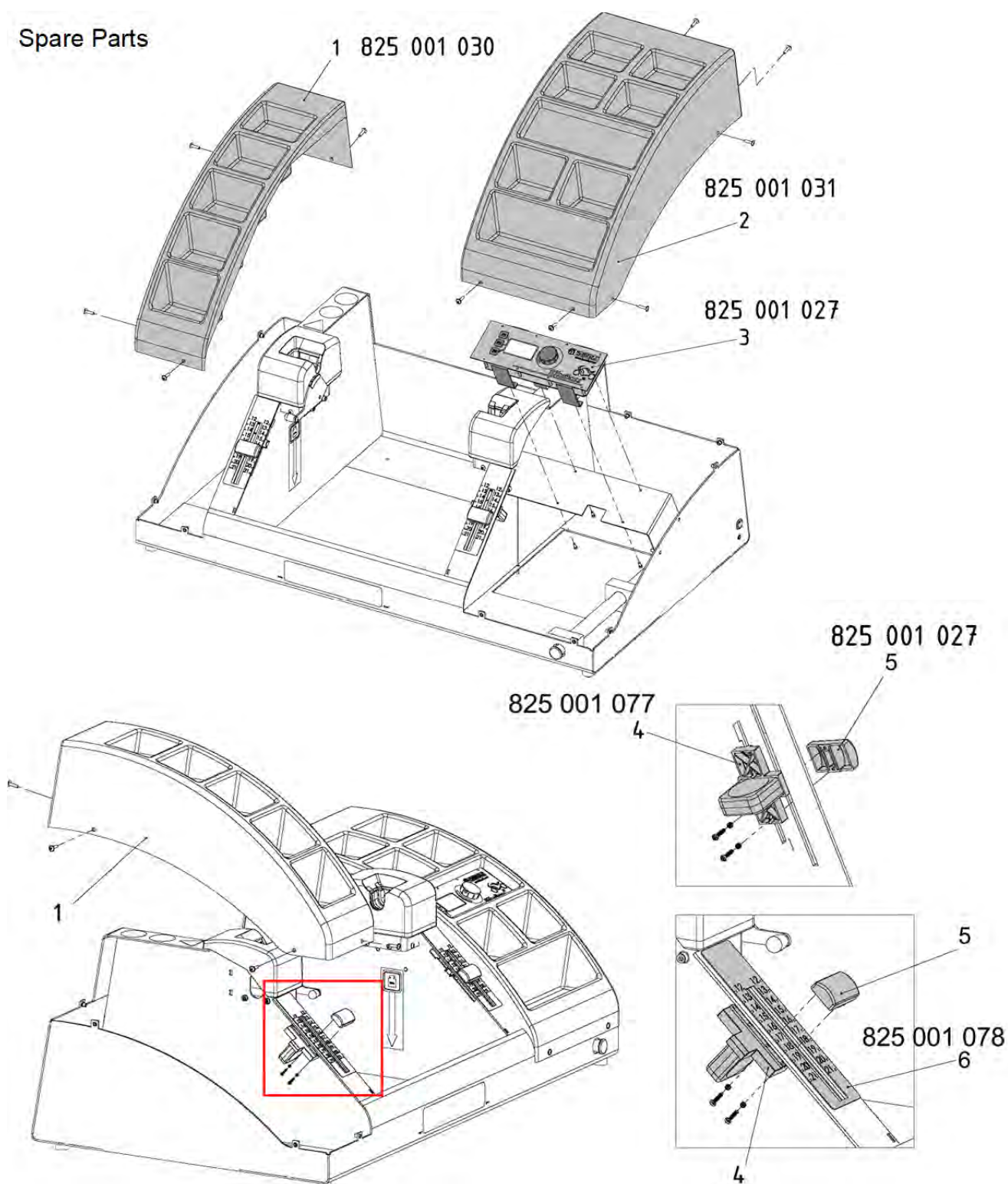

No.	Part no.	Description
1	825 001 030	Left Storage
2	825 001 031	Right Storage
3	825 001 017	Display
4	825 001 077	Measuring tape
5	825 001 027	Sliding Scale Marker
6	825 001 078	Scale

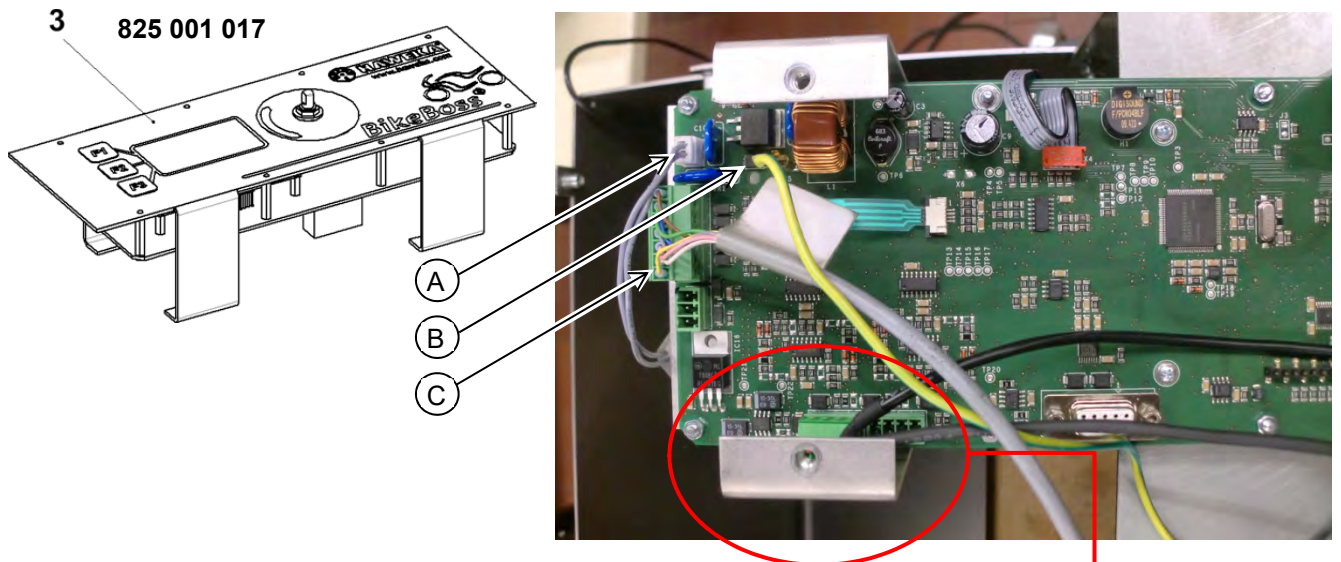

A	Main Electrical connection
B	Earthing cable
C	Encoder connection
D	Piezo left (cable length 1.8m)
E	Piezo right (cable length 0.6m)

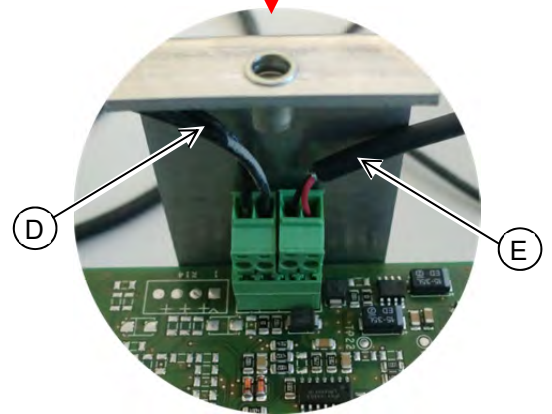

10. Disposal

When the device should be disposed of, please contact with your dealer and ask about the requirements for disposal.

10.1 Instructions for disposal of electrical appliances in the EU member states

The following regulations are applicable when disposing of the device at the end of its service life:

1. The device must NOT be disposed of as house waste, but as special waste.
2. Inform yourself by your dealer about the central waste centres authorized for correct disposal.
3. In order to prevent possible risks to the environment and health, observe the directives for the correct handling of waste.



With your assistance, the quantity of natural resources used for the manufacture of electrical and electronic devices can be reduced, the costs for disposal of the products can be minimized and the quality of life improved.

11. EC Declaration of Conformity

**Haweke AG
Kokenhorststrasse 4
30938 Burgwedel
Germany**

herewith declare that the following device described conforms to the EC Directive in its design and construction, as well as in the design as introduced to the market.

Structural modifications which affect the technical data provided in the Operating Instructions and intended use invalidate this Declaration of Conformity.

Description of the device: BikeBoss

Type of device: Balancing Stand for Motorbike Wheels

Applicable EC Directives: EMC - Directive 2004/108/EEC

National standards applied: DIN EN 61326-1
VDI 4500 Sheet 1

Date / Signature: 22/07/2015



CEO
Dirk Warkotsch



12. Overview of the Motorbike Data

The following lists do not reflect the complete range of applications for the BikeBoss. With this data, we only want to give you assistance for your daily work. Sorted according to manufacturer, the data required for the appropriate motorbike can be quickly found.

The data comes from the individual manufacturers of the motorbikes and are regularly maintained and updated by us.

Should models not be included in the list, we request your understanding, because it is not always easy to record all data and list in printed form. This is applicable for new and also older models.

Should you have questions about data specific to a wheel from other motorbike manufacturers, you can willingly contact us.

Manufacturer overview:

Aprilia / BMW / Buell / Ducati

Harley Davidson / Honda / Hyosung

Kawasaki / KTM / MV Agusta

Suzuki / Triumph / Victory / Yamaha

Aprilia MODEL	AXLE DIAMETER		Note Special Adaptors (P/.No.)
	front	rear	
Classic 125 (1995-2000)	15	17	
Dorsoduro 1200 (2011-)	25	25	
Dorsoduro Factory	25	25	
ETV 1000 Caponord (2001-2009)	25	20	
ETX 125 (1998-2000)	15	17	
Moto 6.5 (1995-2000)	17	17	
NA 850 Mana (2008-)	25	25	
Pegaso 650 (1992-1996)	17	17	
Pegaso 650 Garda (2001-2003)	17	17	
Pegaso 650 Trail (2006-2010)	17	20	
RS 250 (1995-2002)	20	20	
RS 125	20	20	
RST Futura (2001-2003)	20	Mono Lever	For rear Wheel: 1x860e190 012
RSV 1000 R (2006-)	25	25	
RSV 1000 R Factory	25	25	
RSV mille (1998-2003)	20	25	
RSV mille SP	20	25	
RSV4 Factory (2009-)	25	25	
RSV4 R (2010-)	25	25	
RX 125	17	17	
SL 1000 Falco (1999-2004)	20	25	
SL 750 Shiver (2007-)	25	25	
SMV 750 Dorsoduro (2008-)	25	25	
SMV 750 Dorsoduro Factory (2011-)	25	25	
SRV 850 (Scooter) (2013-)	25	30	
Tuono R / Factory (2004-)	25	25	

BMW MODEL	AXLE DIAMETER		Note Special Adaptors (P/No.)
	front	rear	
G 450 X (2008-2011)	25	20	
F 650 all Type	17	19	
F 650 CS SCARVER (2002-2005)	20		For rear Wheel: 1x 860 190 012
F 700 GS (2013-)	12	14	
F 800 GS (2008-)	20	20	
F 800 GT (2013-)	14	Mono Lever	For rear Wheel: 1x 860e190 020
F 800 R (from 2009)	25	20	
F 800 S (2006-2010)	25	Mono Lever	For rear Wheel: 1x 860e190 020
F 800 ST (2006-2012)	25	Mono Lever	For rear Wheel: 1x 860e190 020
G 450 X (2008-2011)	25	20	
G 650 GS (from 2011-)	17	17	
G 650 GS Sertao (2013-)	12	17	
G 650 Xchallenge (2007-2010)	20	20	
G 650 Xcountry (2007-2010)	20	20	
G 650 Xmoto (2007-2010)	20	20	
HP2 Enduro (2006-2007)	25	Mono Lever	For rear Wheel: 1x 860e190 020
HP2 Megamoto (2007-2009)	25	Mono Lever	For rear Wheel: 1x 860e190 020
HP2 Sport (2007-2010)	25	Mono Lever	For rear Wheel: 1x 860e190 020
HP4 (2013-)	25	28	
K 1100 LT (1990-1998)	25	Mono Lever	For rear Wheel: 1x 860e150 015
K 1100 RS (1992-1996)	25	Mono Lever	For rear Wheel: 1x 860e150 015
K 1200 C (2005)	20	Mono Lever	For rear Wheel: 1x 860e190 020
K 1200 GT (2003-2005)	20	Mono Lever	For rear Wheel: 1x 860e150 015
K 1200 GT (from 2006)	25	Mono Lever	For rear Wheel: 1x 860e190 020
K 1200 LT (1999-2009)	20	Mono Lever	For rear Wheel: 1x 860e150 015
K 1200 R (2005-2008)	25	Mono Lever	For rear Wheel: 1x 860e190 020
K 1200 R Sport (2007-2008)	25	Mono Lever	For rear Wheel: 1x 860e190 020
K 1200 RS (1997-2005)	20	Mono Lever	For rear Wheel: 1x 860e150 015
K 1200 S (2005-2008)	25	Mono Lever	For rear Wheel: 1x 860e190 020
K 1300 GT (2009-2011)	25	Mono Lever	For rear Wheel: 1x 860e190 020
K 1300 R (2009-)	25	Mono Lever	For rear Wheel: 1x 860e190 020
K 1300 S (2009-)	25	Mono Lever	For rear Wheel: 1x 860e190 020
K 1600 GT (2011-)	25	Mono Lever	For rear Wheel: 1x 860e190 020
K 1600 GTL (2011-)	25	Mono Lever	For rear Wheel: 1x 860e190 020
K 1600 Sport (2014-)	25	Mono Lever	For rear Wheel: 1x 860e190 020
K 75 RT (1989-1995)	25	Mono Lever	For rear Wheel: 1x 860e150 015
R 100 PD Classic (1990-1996)	25	Mono Lever	For rear Wheel: 1x 860e150 015
R 100 R Classic (1994-1996)	25	Mono Lever	For rear Wheel: 1x 860e150 015
R 100 R Mystic (1993-1996)	25	Mono Lever	For rear Wheel: 1x 860e150 015
R 100 RT Classic (1994-1996)	25	Mono Lever	For rear Wheel: 1x 860e150 015
R 1100 GS (1993-1999)	20	Mono Lever	For rear Wheel: 1x 860e150 015
R 1100 R (1995-2001)	20	Mono Lever	For rear Wheel: 1x 860e150 015

BMW MODEL	AXLE DIAMETER		Note Special Adaptors (P/.No.)
	front	rear	
R 1100 RS (1992-2001)	20	Mono Lever	For rear Wheel: 1x 860e150 015
R 1100 RT (1996-2001)	20	Mono Lever	For rear Wheel: 1x 860e150 015
R 1100 S (1998-2005)	20	Mono Lever	For rear Wheel: 1x 860e150 015
R 1150 GS (1999-2005)	20	Mono Lever	For rear Wheel: 1x 860e150 015
R 1150 GS Adventure (2002-2005)	20	Mono Lever	For rear Wheel: 1x 860e150 015
R 1150 R (2003-2006)	20	Mono Lever	For rear Wheel: 1x 860e150 015
R 1150 RS (2002-2005)	20	Mono Lever	For rear Wheel: 1x 860e150 015
R 1150 RT (2005)	20	Mono Lever	For rear Wheel: 1x 860e190 020
R 1150 RT (2002-2005)	20	Mono Lever	For rear Wheel: 1x 860e150 015
R 1150R Rockster (2003-2005)	20	Mono Lever	For rear Wheel: 1x 860e150 015
R 1200 C (1999-2004)	20	Mono Lever	For rear Wheel: 1x 860e150 015
R 1200 C Independent (2004-2005)	20	Mono Lever	For rear Wheel: 1x 860e150 015
R 1200 GS (2004-2012)	25	Mono Lever	For rear Wheel: 1x 860e190 020
R 1200 GS (2013 -)	25	Mono Lever	For rear Wheel: 1x 860e190 020
R 1200 R (2007-2011)	25	Mono Lever	For rear Wheel: 1x 860e190 020
R 1200 R Classic (2011-)	25	Mono Lever	For rear Wheel: 1x 860e190 020
R 1200 RT (2005-)	25	Mono Lever	For rear Wheel: 1x 860e190 020
R 1200 S (from 2006)	25	Mono Lever	For rear Wheel: 1x 860e190 020
R 1200 ST (2005-2008)	25	Mono Lever	For rear Wheel: 1x 860e190 020
R 850 C (1999-2001)	20	Mono Lever	For rear Wheel: 1x 860e150 015
R 850 GS	20	Mono Lever	For rear Wheel: 1x 860e150 015
R 850 R	20	Mono Lever	For rear Wheel: 1x 860e150 015
R nine T (2015-)	25	Mono Lever	For rear Wheel: 1x 860e190 020
S 1000 R (2014-)	25	28	
S 1000 RR (2010-)	25	28	

BUELL MODEL	AXLE DIAMETER		Note Special Adaptors (P/.No.)
	front	rear	
1125 CR (2009-2010)	25	30	
1125 R (2008-2010)	25	30	
Firebolt XB12 R (2004-2007)	25	30	
Firebolt XB9R (2002-2007)	25	30	
Firebolt XB9S (2003-2007)	25	30	
Lightning City XB9SX (2003-2007)	25	30	
Lightning XB12S (2004-2010)	25	30	
Lightning Long XB12S (2006-2007)	25	30	
M2 Cyclone (1997-2002)	17	25	
S1 Lightning/White L.	17	25	
S3/S3 Thunderbolt (1997-1999)	17	25	
Ulysses XB12X (2006-2010)	25	30	
X1 Lightning (1999-2002)	17	25	

DUCATI MODEL	AXLE DIAMETER		Note Special Adaptors (P/.No.)
	front	rear	
1098 all types (2007-2009)	25	Mono Lever	For rear Wheel: 1x 860e190 004
1198 all types (2009-2011)	25	Mono Lever	For rear Wheel: 1x 860e190 004
1199 Panigale all types (2012 -)	25	Mono Lever	For rear Wheel: 1x 860e190 004
748 all types (1995-2003)	25	Mono Lever	For rear Wheel: 1x 860e190 004
749 all types (2003-2007)	25	30	
848 all types (2008-)	25	Mono Lever	For rear Wheel: 1x 860e190 004
899 Panigale (2014-)	25	25	
916 all types (1995-2003)	25	Mono Lever	For rear Wheel: 1x 860e190 004
996 all types (1998-2001)	25	Mono Lever	For rear Wheel: 1x 860e190 004
998 all types (2002-2003)	25	Mono Lever	For rear Wheel: 1x 860e190 004
999 all types (2003-2006)	25	30	
Desmosedici RR (2007-2008)	25	30	
Diavel (2011-)	25	Mono Lever	For rear Wheel: 1x 860e190 004
GT 1000 (2007-2010)	25	25	
Hypermotard 1100 / 1100 S (2007-)	25	Mono Lever	For rear Wheel: 1x 860e190 004
Hypermotard 1100 Evo SP (2010-)	25	Mono Lever	For rear Wheel: 1x 860e190 004
Hypermotard 796 (2010-)	25	Mono Lever	For rear Wheel: 1x 860e190 004
Hypermotard SP (2013-)	25	Mono Lever	For rear Wheel: 1x 860e190 004
Hyperstrada (2013-)	25	Mono Lever	For rear Wheel: 1x 860e190 004
Monster 1000 (2003-2008)	25	25	
Monster 800 (2003-2007)	25	25	
Monster 1100/S/EVO (2009-)	25	Mono Lever	For rear Wheel: 1x 860e190 004
Monster 1200 S (2014-)	25	Mono Lever	For rear Wheel: 1x 860e190 004
Monster 600 (1994-2001)	17	25	
Monster 620 (2002-2006)	17	25	
Monster 696 (2008-)	25	25	
Monster 750 (1996-2002)	17	25	
Monster 796 (2010-)	25	Mono Lever	For rear Wheel: 1x 860e190 004
Monster 900 (1993-2001)	17	25	
Monster S2R 1000 (2007-2008)	25	Mono Lever	For rear Wheel: 1x 860e190 004
Monster S2R 800 (2005-2007)	25	Mono Lever	For rear Wheel: 1x 860e190 004
Monster S4R 1000 (2007-2008)	25	Mono Lever	For rear Wheel: 1x 860e190 004
Multistrada 1100 /1100 S(2007 - 2009)	25	Mono Lever	For rear Wheel: 1x 860e190 004
Multistrada 1200 all types (2011-)	25	Mono Lever	For rear Wheel: 1x 860e190 004
Multistrada 620 (2005-2006)	25	25	
SS 750 ie Nuda/Carenata (2001-2003)	17	25	
SS 900 ie Nuda/Carenata (1990-2002)	17	25	
ST 2 (1997- 2003)	25	25	
ST 3 (2004-2007)	25	25	
ST 4 (1997-2003)	25	25	
Streetfighter /S 1100 (2010-)	25	Mono Lever	For rear Wheel: 1x 860e190 004

DUCATI MODEL	AXLE DIAMETER		Note Special Adaptors (P/.No.)
	front	rear	
Streetfighter 848 (2012-)	25	Mono Lever	For rear Wheel: 1x 860e190 004
Supersport 800 (2003-2004)	17	25	
Supersport 1000 (2003-2007)	17	25	

Harley Davidson MODEL	AXLE DIAMETER		Note Special Adaptors (P/.No.)
	front	rear	
Bad Boy (1995-1997)	19,05	19,05	
Dyna Fat Bob (from 2008)	25	25	
Dyna Glide Conv.	19,05	19,05	
Dyna Glide Low Rider	19,05	19,05	
Dyna Low Rider (from 2008)	25	25	
Dyna Street Bob (from 2008)	25	25	
Dyna Super Glide	19,05	19,05	
Dyna Super Glide Custom	19,05	19,05	
Dyna Super Glide Custom (from 08)	25	25	
Dyna Super Glide T-Sport	19,05	19,05	
Dyna Wide Glide	19,05	19,05	
Electra Glide (all types)	19,05	19,05	
Electra Glide Standard (from 2008)	25	25	
Fat Boy (from 2008)	25	25	
Fat Boy (all types)	19,05	19,05	
Heritage Softail Classic	19,05	19,05	
Heritage Softail Classic (from 2008)	25	25	
Heritage Springer	19,05	19,05	
Night Rod Special (from 2008)	25	25	
Night Train	19,05	19,05	
Night Train (from 2008)	25	25	
Road King (from 2008)	25	25	
Road King (all types)	19,05	19,05	
Road King Classic (from 2008)	25	25	
Rocker C (from 2008)	25	25	
Screamin Eagle Dyna (from 2008)	25	25	
Screamin Eagle Softail Springer	19,05	25	
Softail Custom	19,05	19,05	
Softail Custom (from 2008)	25	25	
Softail Deluxe (from 2005)	19,05	19,05	
Softail Deluxe (from 2008)	25	25	
Softail Deuce	19,05	19,05	
Softail Springer	19,05	19,05	
Softail Springer Classic	19,05	19,05	
Softail Standard	19,05	19,05	

Harley Davidson MODEL	AXLE DIAMETER		Note Special Adaptors (P/.No.)
	front	rear	
Sportster 1200 (all types)	19,05	19,05	
Sportster 1200 Low (from 2008)	25	25	
Sportster 1200 Nightster (from 2008)	25	25	
Sportster 1200 Roadster (from 2008)	25	25	
Sportster 883 (from 2008)	25	25	
Sportster 883 (from 2008)	25	25	
Sportster 883 Custom (2005)	19,05	19,05	
Sportster 883 Hugger	19,05	19,05	
Sportster 883 Roadster (from 2008)	25	25	
Sportster 883 St	19,05	19,05	
Sportster 883/ Low (2005)	19,05	19,05	
Sportster 883/1200 Custom (from 08)	25	25	
Street Glide (from 2008)	25	25	
Ultra Classic Glide (from 2008)	25	25	
V-Rod (from 2008)	25	25	
V-ROD (all types)	25,4	25,4	1x 860e190 254
XR 1200 (from 2008)	25	25	

From build year 2008 all axis ø 25 mm

Honda MODEL	AXLE DIAMETER		Note Special Adaptors (P/.No.)
	front	rear	
CA 125 Rebel	15	15	
CB 1 (1989-1990)	20	20	
CB 1000 F Super Four (1993-1996)	20	20	
CB 1000 R (2008-)	20	Mono Lever	For rear Wheel: 1x 860e190 011
CB 1100 SF X-11 (2000-2003)	20	20	
CB 1300 (2003-)	20	25	
CB 500 (1994-)	15	17	
CB 500 F	17	17	
CB 500 X	17	17	
CB 750 Seven Fifty (1992-2000)	20	17	
CB 900 F HORNET (2002-2006)	20	17	
CBF 1000 (2006-)	20	20	
CBF 1000 F (2010-)	20	20	
CBF 600 (2004-)	20	20	
CBR 1000 F (1987-2000)	20	20	
CBR 1100 XX S.Blackbird (1997-2008)	20	20	
CBR 125 R (2011-)	12	15	
CBR 250 R (2011-2012)	15	17	
CBR 500 R	17	17	
CBR 600 F (1987-)	20	20	
CBR 600 RR (2003-)	20	25	
CBR 900 RR (1992-2003)	20	20	
CBR125 R (2008-)	12	17	
CLR 125 (1998-2000)	15	15	
CMX 250 Rebel (1996-1999)	15	15	

Honda MODEL	AXLE DIAMETER		Note Special Adaptors (P/.No.)
	front	rear	
CRF 250 L	15	17	
Crossrunner (2011-)	20	Mono Lever	For rear Wheel: 1x 860e190 011
Deauville (2006-2012)	20	20	
DN-01 (2008 - 2011)	20	Mono Lever	For rear Wheel: 1x 860 190 016
Fireblade (2006-)	25	25	
FMX 650 (2005-2007)	17	17	
GB 500 (1989-1990)	15	17	
GL 1500 F6 C Valkyrie (1997-2003)	20	20	
GL 1500 Goldwing (1988-2003)	20	20	
GL 1800 Goldwing (2001-)	20	Mono Lever	For rear Wheel: 1x 860e190 018
Hornet 600 all types (1998-)	20	20	
Integra	20	20	
NC 700 S/ NC700 X	20	20	
NSR 125 R (1994-2003)	15	15	
NTV 650 (1988-1996)	20	Mono Lever	For rear Wheel: 1x 860e190 018
NX 650 Dominator (1988-2000)	15	17	
Pan European ST1300 (2003-)	25	20	
SLR 650 (1997-1998)	20	17	
ST 1100 Pan European (1990-2001)	20	20	
VF 750 C/C2 Shadow ACE	20	20	
VFR 1200 (2010-)	25	Mono Lever	For rear Wheel: 1x 860e190 024
VFR 1200 X Crosstourer (2012-)	20	Mono Lever	For rear Wheel: 1x 860e190 024
VFR 400 R (1986-1991)	20	Mono Lever	For rear Wheel: 1x 860e190 011
VFR 750 F (1986-1997)	20	Mono Lever	For rear Wheel: 1x 860e190 011
VFR 800 also V-TEC (1998-2010)	20	Mono Lever	For rear Wheel: 1x 860e190 011
Vigor 650 (1999-2000)	15	17	
VT 1100 C/C2/C3 (1988-2000)	20	20	
VT 125 C/C2 Shadow (2001-2008)	15	15	
VT 1300 CX Fury (2010-)	20	25	
VT 600 C Shadow (1988-2000)	20	17	
VT 750 (1987-1997)	15	20	
VT 750 (1997-)	20	20	
VTR 1000 Firestorm (1997-2004)	20	20	
VTR 1000 SP1/SP2 (2001-2006)	22	25	
VTX 1300 (2003-2007)	20	20	
XL 1000 V Varadero (1999-)	20	20	
XL 600 V Transalp (1987- 2000)	15	17	
XL 650 V Transalp (2001-2006)	17	17	
XL 700 V Transalp (2007-)	17	17	
XR 125 L	12	17	
XR 400 R (1996-2002)	17	17	
XR 600 (1985-2000)	17	20	
XRV 650/750 Africa Twin (1988-2003)	17	17	

Hyosung MODEL	AXLE DIAMETER		Note Special Adaptors (P/No.)
	front	rear	
GDI250i	15	17	
GT 125 Naked (2009- 2012)	15	17	
GT 250 (all types (2004-)	15	17	
GT 650i (all types 2004-)	15	17	
GV 125 (2000-2010)	15	15	
GV 250i Aquila (all types from 2001-)	15	17	
GV 650i (all types 2006-)	15	17	
ST 700i (2011-)	15	17	
XRX 125 (1999-)	15	15	
XRX 125 SM (2008-)	15	17	

Kawasaki MODEL	AXLE DIAMETER		Note Special Adaptors (P/No.)
	front	rear	
1000 GTR (1986-1993)	15	20	
1000 GTR (1994-2003)	17	20	
1400 GTR (2007-)	25	20	
BJ 250 A/B (1994-1999)	15	17	
BN125 A Eliminator (1998-2007)	15	15	
D-Tracker 125 (2010-)	12	15	
EJ800A: W 800 (2011-)	17	17	
EL 250 (all types 1988-2003)	15	17	
EN 500 (all types 1990-2003)	15	17	
ER 5 Twister (all types 1997-2006)	15	17	
ER-6f (2006-)	20	20	
ER-6n (2006-)	20	20	
GPX 600 R (1988-1996)	15	17	
GPZ 500 S (all types 1987-2003)	15	17	
GPZ 550 (all types 1984-1999)	15	17	
GPZ 600 R (19985-1990)	15	17	
KLE 500 (1991-2007)	15	17	
KLE 650 Versys (2007-)	20	20	
KLR 250 (1984-1992)	15	17	
KLR 650 C (1987-2004)	15	17	
KLV 1000 (2004-2006)	20	20	
KLX 125 (2010-)	12	15	
KLX 250 (all types 1993-)	15	20	
KLX 650 (all types 1993-2001)	15	20	
KLZ 1000 Versys A (2012-)	25	20	
KMX 125 (1992-2003)	17	17	
Ninja 250 R (2008-2012)	15	17	
Ninja 300 (2014-)	15	16	

Kawasaki MODEL	AXLE DIAMETER		Note Special Adaptors (P/No.)
	front	rear	
Ninja ZX 9 R C+D (2006-)	20	20	
Ninja ZX-12R (2000-2006)	25	25	
Ninja ZX-6R (1995-1997)	20	20	
Ninja ZX-6R (1998-)	25	25	
Ninja ZX-6R 636 (2002-)	25	25	
VN 1500 Classic (all types 1996-2004)	20	20	
VN 1500 Drifter (1999-2003)	20	20	
VN 1500 Mean Streak (2002-2003)	25	20	
VN 1600 Classic/Mean Streak/Tourer (2003-2008)	25	20	
VN 1700 Classic Tourer	25	20	
VN 2000 (2004-2010)	25	20	
VN 800 A: VN 800 A (1995-1999)	15	17	
VN 800 AB: VN 800 Classic (1999-2006)	20	17	
VN 800 B: VN 800 B Classic (1996-1998)	20	17	
VN 800 CE: VN 800 E Drifter (1999-2003)	20	17	
VN 900 C Custom (2007-)	20	20	
VN 900 Classic (2006-)	20	20	
VN-15 (all types 1988-1995)	15	20	
W 650 (all types 1999-2005)	15	17	
Z 1000 (2003-2009)	25	25	
Z 1000 (2010-)	20	20	
Z 1000 SX (2011-)	20	20	
Z 1000 Tourer (2014-)	20	20	
ZL 600 (1986-1997)	15	17	
ZR 1100 A+B: Zephyr (1992-1997)	17	20	
ZR 1100 C: ZXR1100 (1997-2000)	25	20	
ZR 550 Zephyr (all types 1984-1999)	15	17	
ZR 750 C Zephyr (1991-1995)	17	17	
ZR 750 D Zephyr (1996-1999)	15	17	
ZR 750 FF: ZR-7 750 F (1999-2004)	17	20	
ZR 750 FH: ZR-7 750 S (2001-2004)	17	20	
ZR 750 J: Z 750 (2004-2006)	20	20	
ZR 750 L: Z 750 (2007-2011)	20	20	
ZR 750 NPA: Z 750 (2011-)	25	20	
ZR800 AA: Z 800 (2013-)	20	20	
ZRX 1200 (all types 2001-2006)	25	20	
ZX 1000 A: ZX-10 (1986-1988)	15	20	
ZX 1100 A: GPZ 1100 Uni-Trak (1981-85)	15	20	
ZX 1100 C: ZZR1100 C (1990-1992)	20	20	
ZX 1100 D: ZZR1100 D (1993-1997)	25	20	
ZX 1100 G: ZZR-1100 (1998-2001)	25	20	
ZX 750 F: GPX 750 R (1987-1988)	15	20	

Kawasaki MODEL	AXLE DIAMETER		Note Special Adaptors (P/No.)
	front	rear	
ZX 750 G: GPZ 750 R (1985)	15	17	
ZX 750 L: ZXR 750 L (1993-1995)	25	25	
ZX 750 P: ZX-7R 750 P Ninja (1996-2002)	25	25	
ZX 900 A: GPZ 900 R (1984-1994)	15	17	
ZX 900 A: GPZ 900 R 1984-1994	15	17	
ZX 900 B: ZX-9R 900 B Ninja 1994-1997	25	25	
ZX 900 B: ZX-9R 900 B Ninja 1994-1997	25	25	
ZX 900 C: ZX-9R 900 C Ninja 1998-1999	20	20	
ZX 900 D: ZX-9R 900 D 1998-1999 Kat	20	20	
ZX 900 E: ZX-9R 900 E Ninja 2000-2003	25	25	
ZX 900 F: ZX-9R 900 F Ninja 2002-2003	25	25	
ZX-10 R 1000 C Ninja (2004-2006)	20	20	
ZX-10 R 1000 D/E/F/J/K Ninja (2006-)	25	20	
ZX-6-RR (2003-2006)	25	25	
ZXR 400 (all types 1989-1999)	20	20	
ZZR 1400 (2006-)	25	25	
ZZR 600 (1990-1992)	15	17	
ZZR 600 (1993-2006)	20	20	

KTM MODEL	AXLE DIAMETER		Note Special Adaptors (P/No.)
	front	rear	
1190 Adventure / R (2013-)	30	25	
1190 RC8 /R (2008-)	26	25	
1190 RC8 R Track (2011-)	30	25	
125 EXE Enduro (1993-	17	20	
125 EXE Supermoto (2000-2001)	17	20	
125 LC2 (1996-2000)	17	20	
690 Duke (2008-)	26	25	
690 Duke R (2010-)	26	25	
690 Enduro (2008-)	26	25	
690 SMC /R (2008-)	26	25	
690 Supermoto (2007-)	26	25	
950 Adventure (LC8) (2003-2005)	26	25	
950 Super Enduro R (2006-2008)	26	25	
950 Supermoto (2006-2008)	26	25	
990 Adventure /S (2006-)	26	25	
990 Adventure/ R (2009-)	26	25	
990 Superduke (2004-2011)	26	25	
990 Supermoto R (2009-)	26	25	
990 Supermoto T (2009-)	26	25	

KTM MODEL	AXLE DIAMETER		Note Special Adaptors (P/.No.)
	front	rear	
Duke 125 (2011-)	15	15	
Duke 200 (2012-)	15	15	
Duke 390 (2013-)	15	15	
Duke I 620 (1994-1998)	17	20	
Duke II 640 E (1998-2007)	17	20	
Freeride 350 (2012-)	22	20	
LC4 400 (1998)	17	20	
LC4 620 (all types 1994-2001)	17	20	
LC4 620 Supermoto (1998)	17	20	
LC4 640 Adventure R (1998-2000)	17	25	
LC4 640 Enduro (1998-2006)	17	20	
Sting 125 (1997-2000)	17	20	
Almost all KTM since 2003 have a 26 mm front axle			
Exceptional: Modele 1190 RC8; Adventure (all types) : ø 30 mm			

MV Agusta MODEL	AXLE DIAMETER		Note Special Adaptors (P/.No.)
	front	rear	
Brutale 1078 RR (2009-2010)	35	Mono Lever	For rear Wheel: 1x 860e190 011
Brutale 1090 RR (2010-)	35	Mono Lever	For rear Wheel: 1x 860e190 011
Brutale 910 (all types 2006-2009)	35	Mono Lever	For rear Wheel: 1x 860e190 011
Brutale 920 (2012-)	35	Mono Lever	For rear Wheel: 1x 860e190 011
Brutale 989 R (2009-2010)	35	Mono Lever	For rear Wheel: 1x 860e190 011
Brutale 990 R (2010-2011)	35	Mono Lever	For rear Wheel: 1x 860e190 011
F3 675 (all types 2012-)	35	Mono Lever	For rear Wheel: 1x 860e190 011
F3 800 (2014 -)	35	Mono Lever	For rear Wheel: 1x 860e190 011
F3 Brutale 675 (2012-)	35	Mono Lever	For rear Wheel: 1x 860e190 011
F4 1000 (all types 2004-)	35	Mono Lever	For rear Wheel: 1x 860e190 011
F4 1078 RR 312 (2009-2010)	35	Mono Lever	For rear Wheel: 1x 860e190 011
F4 750 (all types 2000-2005)	35	Mono Lever	For rear Wheel: 1x 860e190 011
F4 750 Brutale (2003-2005)	35	Mono Lever	For rear Wheel: 1x 860e190 011
Rivale 800	35	Mono Lever	For rear Wheel: 1x 860e190 011

For front Wheel: 1x 860 190 350 (all types)
--

Suzuki MODEL	AXLE DIAMETER		Note Special Adaptors (P/.No.)
	front	rear	
AN 650 (Roller) (2002-)	17	Keilwelle	
Bandit 650 (all types 2005-2006)	17	20	
Bandit 650 (all types 2007-)	20	20	
B-King (2008-2012)	25	28	
DL 1000 V-Strom (2002-2010)	20	20	
DR 125 (all types 1982-)	12	15	
DR 350 (all types 1990-1997)	15	20	
DR 600 S/R (1986-1989)	15	17	
DR 650 R/RE/RSE (1990-1995)	15	17	
DR 650 SE (1996-2000)	17	20	
DR 750/800 S BIG (1988-1999)	15	17	
DR-Z 400 (all types 2001-2008)	20	20	
GN 125 (1994-1999)	12	15	
GN 250 (1985-1999)	15	15	
GS 500 (all types 1979-2008)	15	17	
GSF 1200 Bandit (2001-2005)	20	20	
GSF 1200 Bandit (2006)	25	28	
GSF 1250 Bandit (2007-)	25	28	
GSF 400 Bandit (1991-1995)	15	17	
GSF 600 Bandit (1995-2004)	17	20	
GSR 600 (2006-2011)	22	25	
GSX 750 (1980-1983)	15	20	
GSX 750 (1998-2003)	20	20	
GSX 1100 F (1988-1996)	17	20	
GSX 1100 G (1984-1986)	15	17	
GSX 1200 Inazuma (1999-2000)	20	20	
GSX 1300 R Hayabusa (1999-2007)	25	32	
GSX 1300 R Hayabusa (2008-)	25	28	
GSX 1400 (2005-2007)	28	32	
GSX 600 F (1988-2001)	15	17	
GSX 650 F (2008-)	20	20	
GSX 750 F (1989-2006)	15	17	
GSX-R 1000 (2001-2008)	25	28	
GSX-R 1000 (2009-)	25	32	
GSX-R 1100 (1986-1988)	15	20	
GSX-R 1100 (1989-1997)	20	20	
GSX-R 600 (1997-2000)	25	32	
GSX-R 600 (2001-2003)	25	28	
GSX-R 600 (2004-2005)	25	28	
GSX-R 600 (2006-)	25	28	
GSX-R 750 (1985-1988)	15	20	
GSX-R 750 (1987)	17	20	
GSX-R 750 (1988-1995)	20	20	
GSX-R 750 (1996-1999)	25	32	
GSX-R 750 (2000-2010)	25	28	
GSX-R 750 R (1986)	15	25	
GZ 125 Marauder (1998-)	12	15	
GZ 250 Marauder (1999-2008)	15	15	
LS 650/P Savage (1986-2000)	15	17	
RF 600 (all types 1993-1996)	15	25	
RF 900 R/RS2 (1994-1997)	20	20	
RG 500 Gamma (1985-1989)	15	17	
RV 125 VanVan (2003-)	15	15	
SV 1000 /1000 S (2003-2005)	25	28	
SV 650 (all types 1999-2002)	17	17	

Suzuki MODEL	AXLE DIAMETER		Note Special Adaptors (P/.No.)
	front	rear	
SV 650 (all types 2003-2010)	17	20	
SVF 650 Gladius (2009-)	17	20	
TL 1000 S/R (1997-2000)	25	32	
VL 125 Intruder (2001-2008)	15	15	
VL 1500 LC Intruder (1998-)	17	20	
VL 250 Intruder (2000-2007)	15	15	
VLR 1800 Intruder C1800 (2008-2012)	25	25	
VS 1400 Intruder (1987-2003)	15	17	
VS 600 GL Intruder (1995-1997)	15	17	
VS 800 GL Intruder	15	17	
V-Strom 650 (2004-2010)	17	20	
VX 800 (1990-1997)	15	17	
VZ 800 Marauder (all types 1997-)	17	17	
VZR Intruder M1800R (2006-)	25	25	
XF 650 Freewind (1997-2002)	17	20	

Triumph MODELL	AXLE DIAMETER		Note Special Adaptors (P/.No.)
	front	rear	
Adventurer 900 (1996-2001)	25	20	
America 865 (2001-)/Speedmaster	25	20	
Bonneville 800 SE (2009-)	17	17	
Bonneville 865 T100 (2005-)	17	17	
Daytona 1200 (1993-1997)	25	20	
Daytona 600 (2003-2004)	20	20	
Daytona 675 / R (2006-)	20	20	
Daytona 900 (1993-1996)	25	20	
Daytona 955i (1997-2001)	20	Mono Lever	For rear Wheel: 1x 860e190 024
Daytona 955i (2002-2006)	20	25	
Daytona Super III (1994-1996)	25	20	
Legend 900 TT (1999-2001)	25	20	
ROCKET 2300 III (all types) (2004-)	20	20	
Scrambler 865 (2006-)	17	17	
Speed Four (2003-2005)	20	20	
Speed Triple (1050) 2011	20	Mono Lever	For rear Wheel: 1x 860e190 022
Speed Triple 1050 (2005-2010)	25	Mono Lever	For rear Wheel: 1x 860e190 024
Speed Triple 900/955 (1997-2001)	17	Mono Lever	For rear Wheel: 1x 860e190 024
Speed Triple 955 (2002-2004)	20	Mono Lever	For rear Wheel: 1x 860e190 024
Speedmaster 800/865 (2003-)	25	20	
Sprint GT 1050 (2011-)	25	Mono Lever	For rear Wheel: 1x 860e190 022
Sprint RS 955 (2000-2001)	25	20	
Sprint RS 955 (2004)	25	Mono Lever	For rear Wheel: 1x 860e190 024
Sprint ST 1050 (2005 -2011)	25	Mono Lever	For rear Wheel: 1x 860e190 024
Street Triple / R (675) (2007-)	20	20	
T 595 Daytona 955 (T595/502 955i)	25	Mono Lever	For rear Wheel: 1x 860e190 024

Triumph MODELL	AXLE DIAMETER		Note Special Adaptors (P./No.)
	front	rear	
Thruxton 865 (2004-)	17	17	
Thunderbird 900 (all types) (1995-2004)	20	20	
Tiger 1050 Sport (2013-)	25	Mono Lever	
Tiger 1050 Sport / SE (2007-2012)	25	20	
Tiger 800 (2011-)	20	20	
Tiger 800 XC (2011-)	20	20	
Tiger 900 / 955i (1993-2006)	17	17	
Tiger Explorer (2012-) 1215ccm	20	Mono Lever	For rear Wheel: 1x 860e190 022
Tiger Explorer XC (2013-) 1215ccm			For rear Wheel: 1x 860e190 022
Tiger Sport (2013-) 1050ccm	20	Mono Lever	
Trident 750 (1992-1998)	25	20	
Trident 900 (1993-1998)	25	20	
Trophy 1200 (1993-2003)	25	20	
Trophy 1200 / SE (2013-)	20	Mono Lever	
Trophy 900 (1993-2001)	25	20	
TT 600 (2000-2003)	20	20	

Victory MODELL	AXLE DIAMETER		Note Special Adaptors (P./No.)
	front	rear	
Boardwalk	20	20	
Cross Country	20	20	
Cross Roads	20	20	
Hammer	20	20	
Kingpin	20	20	
Vegas	20	20	
Vegas Jackpot	20	20	
Vision Tour	20	20	

Yamaha MODELL	AXLE DIAMETER		Note Special Adaptors (P./No.)
	front	rear	
BT 1100 Bulldog (2002)	17	17	
BT 1100 Bulldog (2003-2006)	22	17	
DT 125 R (1991-2006)	15	20	
FJ 1100 (1984-1985)	15	20	
FJ 1200 (1986-1997)	15	20	
FJR 1300 (2001-2002)	22	20	
FJR 1300 (2002-)	17	22	
FJR 1300 A	22	20	
FZ 1 (2007-)	22	28	

Yamaha MODELL	AXLE DIAMETER		Note Special Adaptors (P./No.)
	front	rear	
FZ 1 Fazer (2006-)	22	28	
FZ 750 (1985-1994)	15	17	
FZ6 600 Fazer/ S2 (2004-2009)	22	28	
FZR 1000 (1987-1988)	15	17	
FZR 1000 (1989-1993)	17	20	
FZR 1000 (1994-1995)	22	20	
FZR 600 (1989-1993)	15	17	
FZR 600 (1994-1995)	17	20	
FZR 600 R (1994-1995)	17	20	
FZR 750 R (1987-1988)	15	17	
FZR 750 R (1989-1992)	17	20	
FZS 1000 + S (2001-2005)	22	28	
FZS 600 Fazer (1998-2003)	17	20	
FZX 750 (1987-1989)	15	17	
GTS 1000	LK100	20	For front Wheel: 1x 860e190 012
MT-01 (2005-2012)	22	28	
MT-03 (2006-)	22	17	
RD 350 LC (1980-1989)	12	15	
RD 500 (1984-1985)	15	17	
SR 125 (1989-2002)	15	15	
SR 500 all types	17	17	
SRX 600 (1986-1987)	15	17	
SZR 660 (1995-1996)	17	15	
TDM 850 (1991-2001)	17	17	
TDR 125 (1997-2002)	15	17	
TDR 250 (1988-1989)	15	20	
TRX 850 (1996-1999)	17	20	
TT 600 S/R (1993-2004)	17	20	
TW 125 (1999-2003)	15	17	
TZR 125 (1997-1999)	17	15	
TZR 250 (1987-1990)	15	12	
V-max (1984-2006)	17	20	
V-max (2009-)	22		
WR 250 R (2008-)	17	22	
WR 250 X (2008-)	17	22	
WR 400 F (1998-2002)	20	20	
XJ 550 (1981-1984)	15	17	
XJ 6 (2009-)	17	17	
XJ 6 Diversion (2009-)	17	17	
XJ 600 (1984-1991)	15	17	
XJ 600 S/N (1992-2003)	17	17	
XJ 650 (1980-1985)	15	17	

Yamaha MODELL	AXLE DIAMETER		Note Special Adaptors (P./No.)
	front	rear	
XJ 750 (1982-1985)	15	17	
XJ 900 all types (1983-2003)	15	17	
XJR 1200 (1995-1998)	17	20	
XJR 1300 (1999-2001)	22	20	
XJR 1300 (2002-)	22	28	
XP 500 T max. (2001-2007)	15	17	
XP 500 T max. (2008-2011)	22	17	
XP 500 T-max (2001-)	15	17	
XS 1100 (1980-1983)	17	20	
XS 400 (1980-1984)	15	17	
XS 650 / 650 SE (1977-1983)	17	20	
XS 750 /750 SE (1977-1982)	17	20	
XS 850 (1980-1982)	17	20	
XT 125 R (2005-2012)	15	15	
XT 125 X (2005-2011)	15	15	
XT 350 (1985-1995)	15	17	
XT 600 (1986-2003)	15	17	
XT 600 Z Tenere (1985-1991)	15	17	
XT 660 R (2005-)	17	17	
XT 660 X (2005-)	17	17	
XT 660 Z Tenere (2008-)	17	17	
XTZ 660 Tenere (1991-1995)	15	17	
XTZ 750 (1989-1997)	15	17	
XV 1000 SE (1983-1985)	15	17	
XV 1000 TR1 (1981-1984)	15	20	
XV 1000 Virago (1986-1988)	15	17	
XV 1100 (1989-1999)	15	17	
XV 125 (1997-2001)	15	15	
XV 1600 (1999-2004)	22	20	
XV 1700 Road Star Warrior (03-05)	22	20	
XV 1900 Midnight Star (2006-)	22	20	
XV 250 (1989-2000)	15	15	
XV 500 (1983-1984)	15	15	
XV 535 (1988-2003)	17	15	
XV 750 (1981-1997)	15	17	
XVS 1100 all (1999-2005)	17	17	
XVS 1300 A (2007-)	17	20	
XVS 650 (1997-2007)	17	15	
XVS 950 A Midnight Star (2009-)	17	20	
XVZ 12 T (1984-1985)	17	20	
XVZ 13 T (1989-1992)	17	20	
XVZ 1300 all (1996-2001)	22	20	

Yamaha MODELL	AXLE DIAMETER		Note Special Adaptors (P./No.)
	front	rear	
XZ 550 (1982-1984)	15	17	
YBR 125 (2005-)	15	15	
YZF 1000 R Thunderace (1996-2001)	22	28	
YZF 600 R Thundercat (1996-2002)	17	20	
YZF 750 (1993-1998)	22	28	
YZF R 125 (2008-)	15	15	
YZF R1 (1998-)	22	28	
YZF-R6 (1999-)	22	28	
YZF-R7 (1999-2000)	22	28	



HAWEKA AG

Kokenhorststraße 4 ♦ 30938 Burgwedel
Tel. 05139/8996-0 ♦ Fax 05139/8996-222
www.haweke.com ♦ Info@haweke.com